

Performance criteria

Tested according to	EN 1906
with 9 mm square spindle fire protection tested according to DIN 18273	F
Lever handle shape suitable for emergency exits and fire barrier doors	EN 179
Return spring (type A)	■
Fixed swivel-mounted lever handle	■
Steel substructure with supporting cams	■
Concealed, continuous screw attachment	■
DIN L / R	□

Classification key EN 1906

4	7	-	B1	1	4	0	A
---	---	---	----	---	---	---	---

■ Yes - No □ Optional

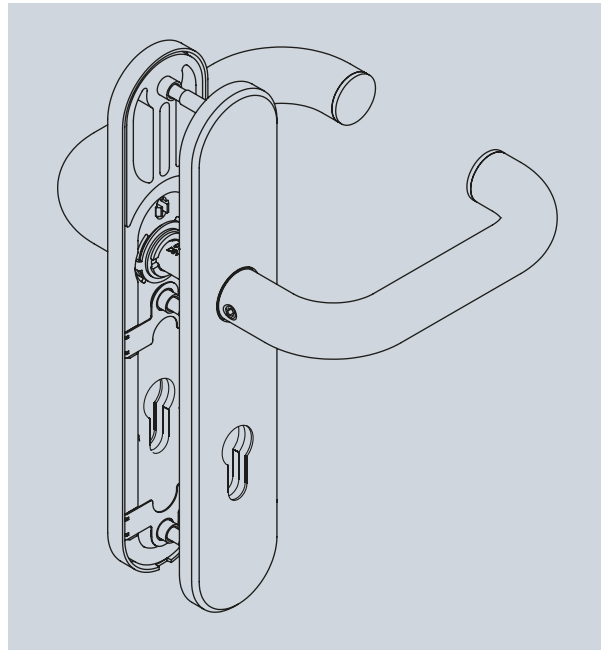

Steel door



Wooden door

Material:



ER
Stainless steel

Bearing technology:



OGL - HANDLE ON LONG PLATE (L)

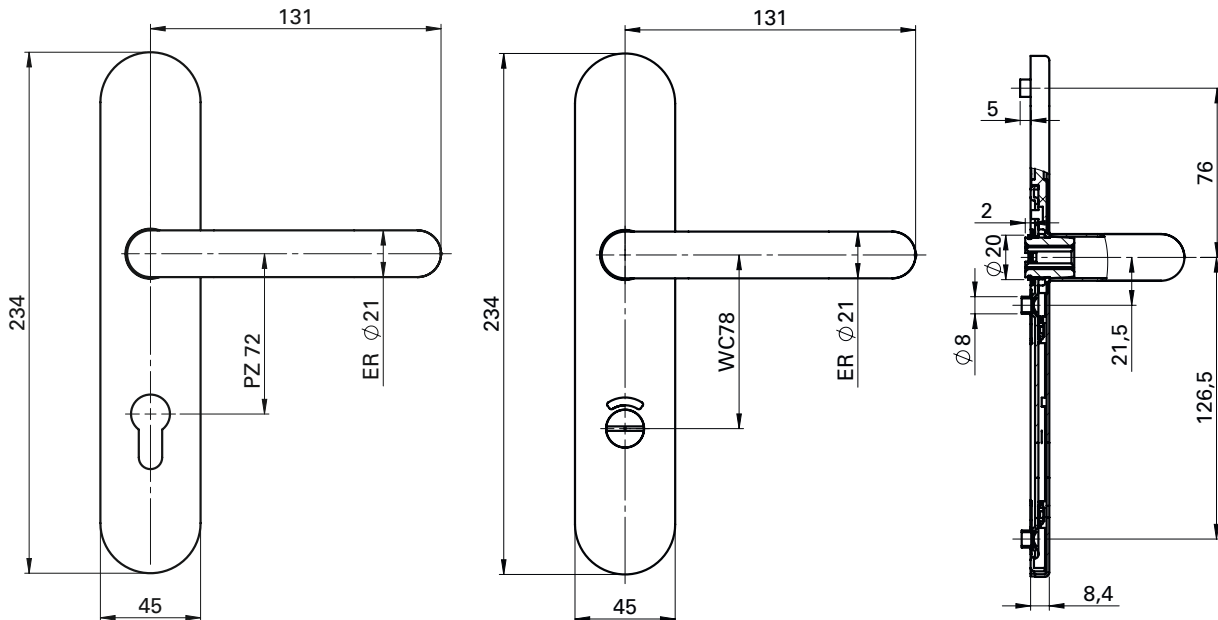

D-110 long plate (L) round



D-110 long plate (L) with OGL – friction bearing technology

Lever handle guidance with a maintenance-free friction bearing made of self-lubricating nylon. Fixed swivel-mounted lever handle. Steel/nylon substructure with positioning studs. Concealed, continuous screw attachment. Please note the DIN direction for knob/lever and WC handles.

User category class 4, supporting cams Ø 8 x 5 mm

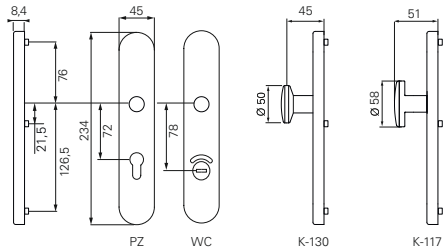

OGL – HANDLE ON LONG PLATE (L)

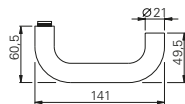

EN 1906 EN 179 F

F = 4 7 - B1 1 4 0 A



		Fittings set							
	Ø	∇	PZ	WC-SK L	WC-SK R	K-130 L	K-130 R	K-117 L	K-117 R
S	21 mm	8 mm	5030066575	5030066578	5030066581	5030066593	5030066594	5030066592	5030066591
F	21 mm	9 mm	5030066573			5030066586	5030066588	5030066589	5030066590

Finish: matt brushed. Please note the DIN direction L or R.

Lever handle facing left-WC long plate with escutcheon

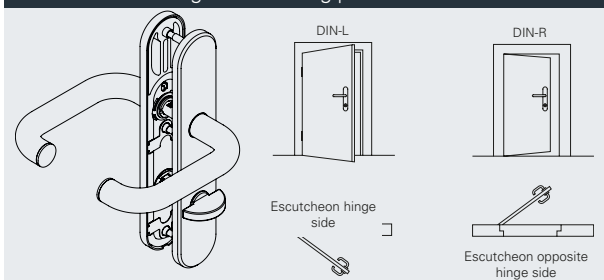

Lever handle facing right-WC long plate with escutcheon

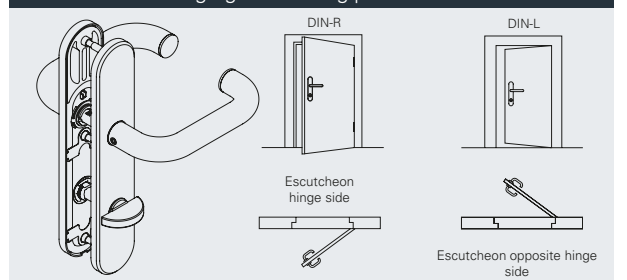

S Standard fitting for door thicknesses: 38–45 mm. **F** Door thicknesses for fire doors: 44–66 mm. Fittings for other door thicknesses available on request.

Performance criteria

Tested according to	EN 1906
with 9 mm square spindle fire protection tested according to DIN 18273	F
Lever handle shape suitable for emergency exits and fire barrier doors	EN 179
Return spring	-
Fixed swivel-mounted lever handle	■
Steel substructure with supporting cams	■
Concealed, continuous screw attachment	■
DIN L / R	■

Classification key EN 1906

4	7	-	B	1	4	0	U
---	---	---	---	---	---	---	---

■ Yes -No □ Optional

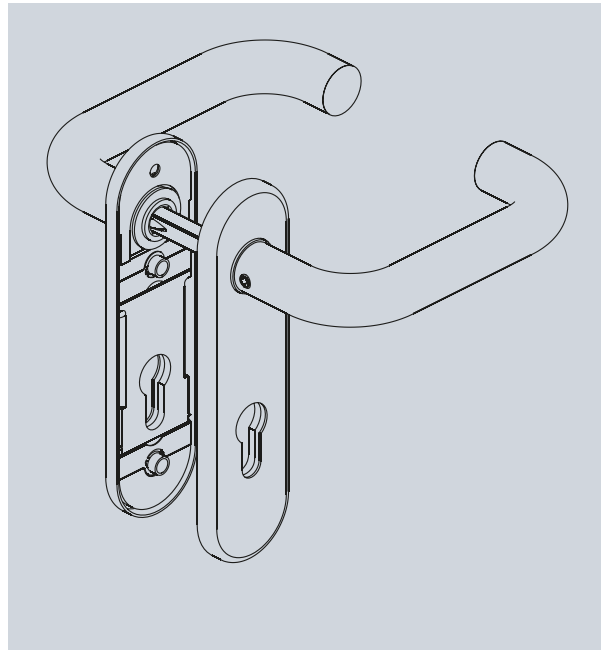

Steel door



Wooden door

Material:



ER Stainless steel



Al Aluminium



Ku Nylon

Bearing technology:



D-110 short plate (K) round



D-110 short plate (K) with OGI – friction bearing technology

Lever handle guidance with a maintenance-free friction bearing made of self-lubricating nylon. Fixed swivel-mounted lever handle. Can be used for DIN left/DIN right. Steel substructure with positioning studs. Non-visible, continuous screw attachment. User category class 4, supporting cams $\varnothing 8 \times 5$ mm

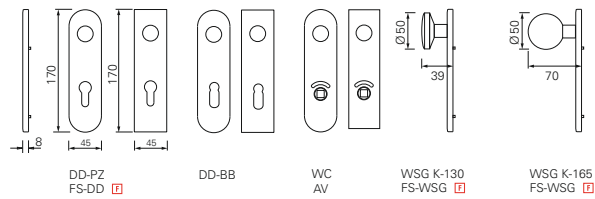

OGI – HANDLE ON SHORT PLATE (K)

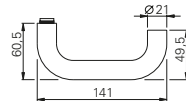

EN 1906 EN 179 F

F = 4 7 - B1 1 4 0 U



			Fittings set					Passive leaf fittings set		
	\varnothing	∇								
	21 mm	8 mm		106505.46	106500.46	106510.46	106560.46	106520.46		
	21 mm	9 mm	306081.46	306100.46		306200.46	306263.46		306125.46	306319.46 306317.46
	21 mm	9 mm		306150.46						

Finish: matt brushed. PVD and polished on request.

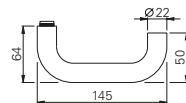

EN 1906 EN 179 F

F = 4 7 - D1 1 4 0 U



			Fittings set					Passive leaf fittings set		
	\varnothing	∇								
	22 mm	8 mm			107505.30	107500.30	107510.30	107520.30		
	22 mm	9 mm	307081.30	307083.30	307100.30		307200.30		307104.30	307320.30 307317.30
	22 mm	9 mm			307150.30					

Finish: F1 anodised aluminium; further colours available on request.



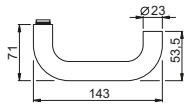





UGL – HANDLE ON SHORT PLATE (K)



EN 1906 EN 179  **F**

F = 3 7 - D1 1 4 0 U



			Fittings set					Passive leaf fittings set	FS knob K-130 / short plate	
	∅	∇								
S	23 mm	8 mm	104505	104500	104510	104520				
F	23 mm	9 mm	304100		304200		304108	304317	324040	324042
	23 mm	9 mm	304150							

Material: Nylon · Glossy finish

Note: 6 mm deep-drawn lever handle guidance. Lever handle with continuous steel core. User category class 3. Compatible drilling template available, art. no.: 930317



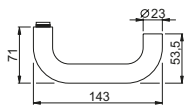





 Black  Dark grey  White  Red  Blue Further colours available on request.



EN 1906 EN 179  **F**

F = 3 7 - D1 1 4 0 U



			FS half handle set		FS short plate		Fittings set		Passive leaf fittings set	
	∅	∇								
F	23 mm	9 mm	314200.02	314202.02	344034.02	324033.02	304600.02	304700.02	304601.02	304617.02
	23 mm	9 mm					304650.02			

Material: Black nylon · Glossy finish



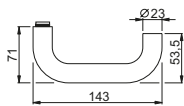





Note: 6 mm deep-drawn lever handle guidance. Lever handle with continuous steel core. User category class 3. Compatible drilling template available, art. no.: 930317



EN 1906 EN 179  **F**

F = 3 7 - D1 1 4 0 U



			Fittings set					Passive leaf fittings set		FS knob K-130 / short plate	
	∅	∇									
F	23 mm	9 mm	313600.02	313808.02	313600.02	313700.02	313601.02	313318.02	313617.02	333750.02	
	23 mm	9 mm			313650.02					324022.03	

Material: Black nylon · Matt finish with glossy edge

6 mm deep-drawn lever handle guidance. Lever handle with continuous steel core. User category class 3.

Compatible drilling template available, art. no.: 930317

D-110 short plate (K) rectangular



D-110 short plate (K) with OGL – friction bearing technology

Lever handle guidance with a maintenance-free friction bearing made of self-lubricating nylon. Fixed swivel-mounted lever handle. Can be used for DIN left/DIN right. Steel substructure with supporting cams. Non-visible, continuous screw attachment. User category class 4, supporting cams Ø 8 x 5 mm

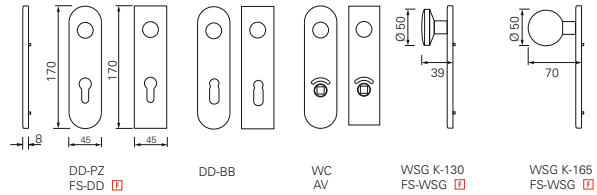

OGL – HANDLE ON SHORT PLATE (K)

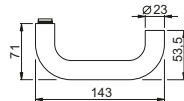

EN 1906 EN 179 F

F = 3 7 - D1 1 4 0 U

	Ø	▧	Fittings set				Passive leaf fittings set		FS knob K-130 / short plate		
	23 mm	9 mm			319601.02	319701.02	319603.02	319605.02	319604.02	324276.02	120473.02
	23 mm	9 mm	319601.02	319603.02	319602.02						

Material: PPN nylon, black · Matt finish
 6 mm deep-drawn lever handle guidance. Lever handle with continuous steel core. User category class 3.
 Compatible drilling template available, art. no.: 930317

Product information and use of ECO fitting technology

§ 1 Product information and intended usage

1. The fitting systems made by ECO are assistive systems that can be used to help with opening and closing motions and/or locking processes for doors, glass doors and window elements.
2. The fixing elements supplied with these products must be used and installed according to the mounting instructions/specifications.

§ 2 Improper use of the products

Improper use of fitting systems for doors and windows (i.e. not using the product as intended) includes the following situations in particular:

- Installation or mounting of foreign objects and/or objects not intended for this purpose into the fitting system;
- Using auxiliary tools to operate the system;
- The fittings are used as a replacement for a missing wall buffer;
- Fittings are misused as a suspension device for heavy loads;
- Fittings are used long-term in combination with panic locks instead of only in emergencies, against the recommendation of the lock and fitting industry;
- Surface of the fitting systems damaged by the use of sharp or hard objects;
- The use of fasteners made by third-party manufacturers.

Sooner or later, these errors will cause damage, and the products will no longer have the characteristics defined by the manufacturer.

§ 3 Product performance

1. Product performance is only partially governed by standards. Many aspects of product performance have been developed based on years of experience and should be considered common knowledge in the construction hardware industry. Correspondingly, the contents of these standards and these empirical values should also be applied to fittings that are not expressly regulated.
2. Specifically, the following standards apply:
 - EN 1906: General benchmarks for door fittings and accessories;
 - DIN 18273: Special rules for fire and smoke control doors;
 - DIN 18257: Minimum security requirements for security fittings.
3. The fitting system must be replaced if, despite maintenance and servicing, it can no longer be ensured that it will function properly, and/or it may pose a risk of injury.
4. Furthermore, the products are continuously being improved, and manufacturing is subject to quality assurance. The right to make technical changes is reserved.

§ 4 Product maintenance

1. The user must ensure that the fitting systems and fixing elements are installed in a proper functional manner.
2. Depending on the material and where they are used, the products will face a certain degree of natural wear and tear. Consequently, all moving parts must undergo maintenance at least once per year; i.e. the proper fit, stability of the screw connections etc. must be checked on a regular basis. Only water, gentle cleaning agents and other cleaning agents that do not contain corrosive ingredients should be used for cleaning the fitting systems.
3. Manufacturing primarily uses the materials nylon, aluminium, stainless steel and brass. Please note that each of these different materials has different maintenance and servicing requirements.

§ 5 Duty to inform and instruct

1. The following documents are available to provide information and instruction:
 - Catalogues and brochures;
 - Tender documents;
 - Procurement information;
 - Bid documents;
 - Installation and operating instructions;
 - DIN standards.
2. In order to ensure that the fitting systems function properly:
 - Architects, planners and any other people involved in the process are required to request all the necessary product information from us and to comply with said information,
 - Specialised retailers are required to observe the product information and notes in the price lists and catalogues and, in particular, to request all required instructions from us and to pass them on to the processors,
 - The processors are required to obtain all product information and to comply with it, and, in particular, to request the operating and maintenance instructions from us and pass them on to the customers and users.

Overall, all parties involved must ensure that the fitting systems are properly assembled and installed and that each end user receives proper instructions and explanations.

General information

ECO Schulte recommends

For lever handle sets without a return spring, we recommend using locks that comply with DIN 18251 - class 3 or higher

In order to minimise the clearance between the lever handle set and the lock, we recommend locks that comply with DIN 18251 with a clamping nut.

When ECO handles are properly installed and used, the paint should withstand daily use. Excessive contact with hard or sharp objects (such as key rings, rings etc.) can scratch the surface. This does not impair functionality, however.

Our Compendium presents a compilation of all the products in our range. These are each subject to different supply classes. Special models are often configured to specific customer wishes and sometimes require longer lead-times and minimum order quantities. Your contact will be happy to advise you.

ECO Schulte GmbH & Co. KG

Iserlohner Landstraße 89

D-58706 Menden

Telephone +49 2373 9276 - 0

Telefax +49 2373 9276 - 40

info@eco-schulte.de

www.eco-schulte.de

Our compendium represents a compilation of all products from our range of services. These are subject to different delivery classes. Special variants included are often manufactured to customer specifications and sometimes require longer delivery times and minimum purchase quantities. Further advise can be given by your contact person.

■ SYSTEM TECHNOLOGY FOR THE DOOR

