

222 $\pm$ 1

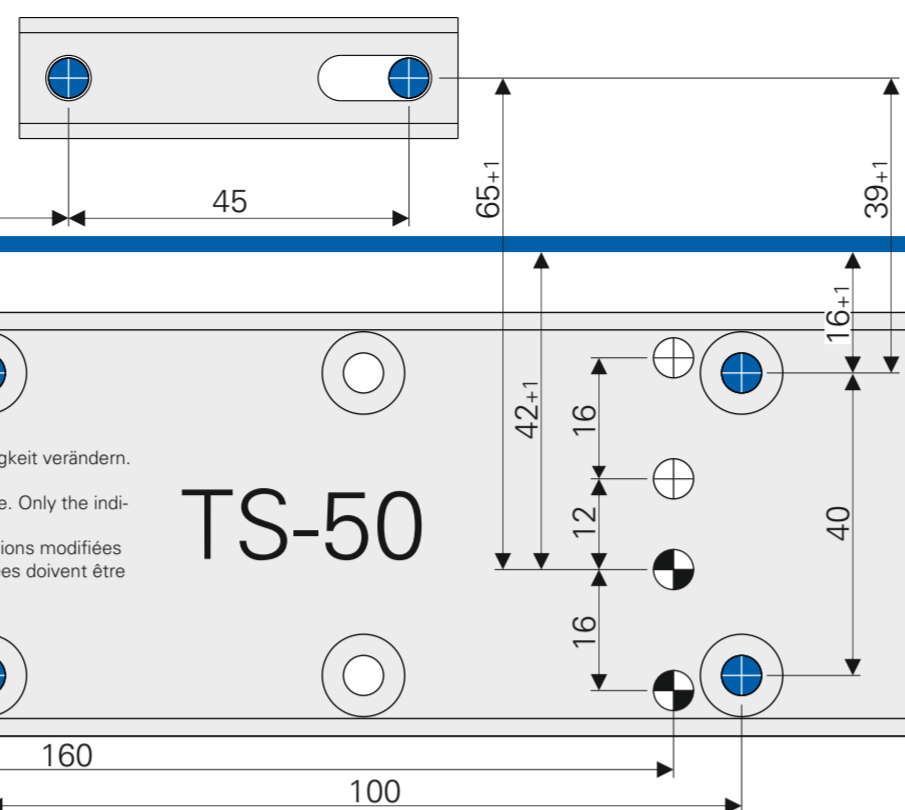

Ø 2,5  
Ø 4,2 (M5)

Bohrungen für Montageplatte gemäß Beiblatt 1 zur DIN EN 1154  
Drillings for mounting plate according to supplemental sheet 1 DIN EN 1154  
Alésage pour platine de montage selon supplément 1 DIN EN 1154

Bohrungen für Direktmontage  
Drillings for direct mounting  
Alésage pour montage direct

Papierschablonen können sich durch Luftfeuchtigkeit verändern. Verbindlich sind daher nur die Maßangaben. Paper templates might distort due to air moisture. Only the indicated measurements are therefore obligatory. Les gabarits en papier peuvent avoir des dimensions modifiées par l'humidité de l'air. Seules les côtes mentionnées doivent être respectées.

TS-50

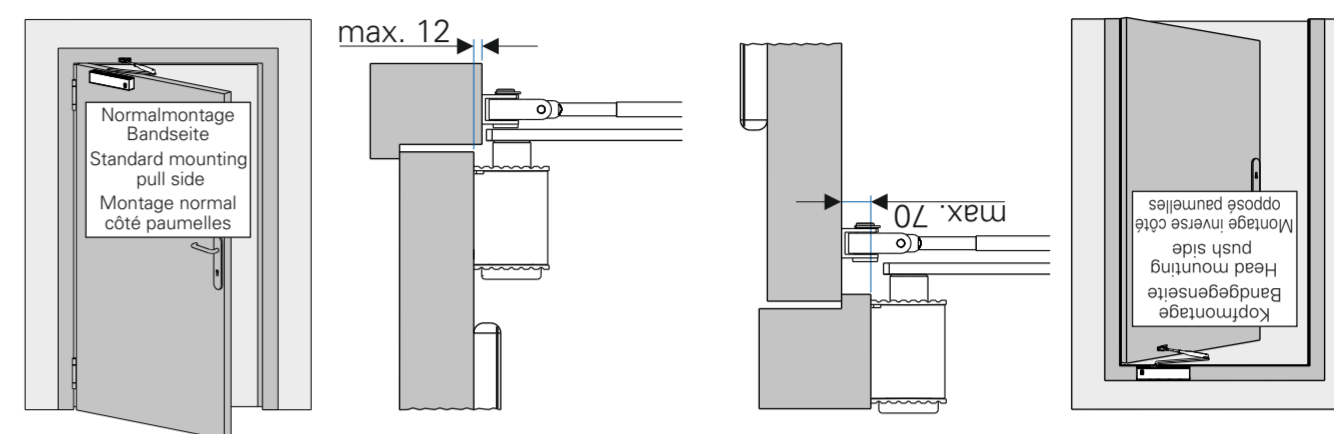

DIN links / left / gauche

TS-50 EN 2-6

CE	ECO Schulte GmbH & Co. KG Iserlohner Landstraße 117 D-58706 Menden	17
0432-CPR-00099-10	EN 1154:1996+A1:2002 / AC:2006	4 8 2-6 1 1 4

TS-50 EN 2-6	Türschließergröße Door closer size Force de ferme porte	Max. Türbreite Max. door width Largeur de porte max.	Umdrehungen Rotations Rotations
■ 2	850 mm	-3	
■ 3	950 mm	0	
■ 4	1100 mm	+3	
■ 5	1250 mm	+7	
■ 6	1400 mm	+11	

Für die Montage dürfen ausschließlich Originalteile des Herstellers verwendet werden. Die Montagearbeiten müssen gemäß Anleitung von einer qualifizierten Person durchgeführt werden. Bei Nichtbeachtung entfällt jeglicher Garantieanspruch. Diese Anleitung ist vom Monteur nach der Montage an den Betreiber weiterzugeben.  
Only original parts have to be used. The assembly has to be made by a qualified person according to the mounting instruction. In case of non-respect the guarantee is invalid. This instruction is to be handed over to the operator by the fitter after assembly!  
Impérativement utiliser la notice de montage fournie par le fabricant. La mise en œuvre et le montage doivent être exécutés par du personnel qualifié. Le non respect de ces règles annule catégoriquement tout droit de garantie. Cette instruction est à remettre par le poseur à l'exploitant après montage.

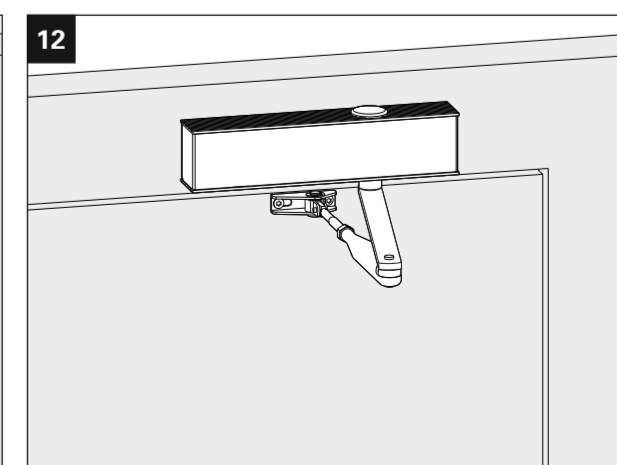
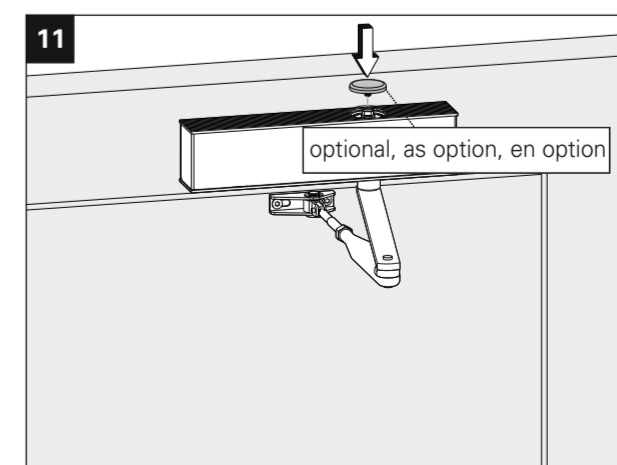
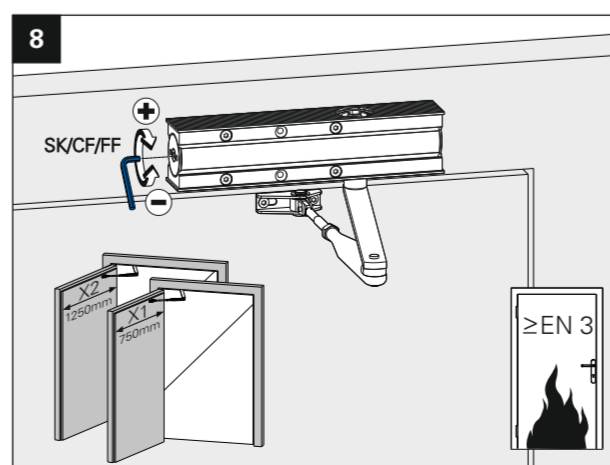
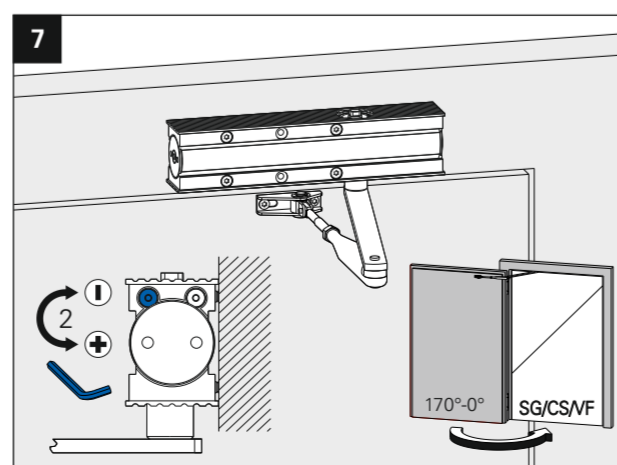
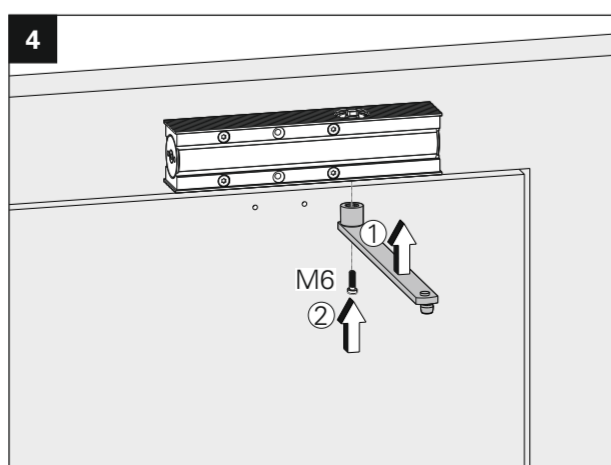
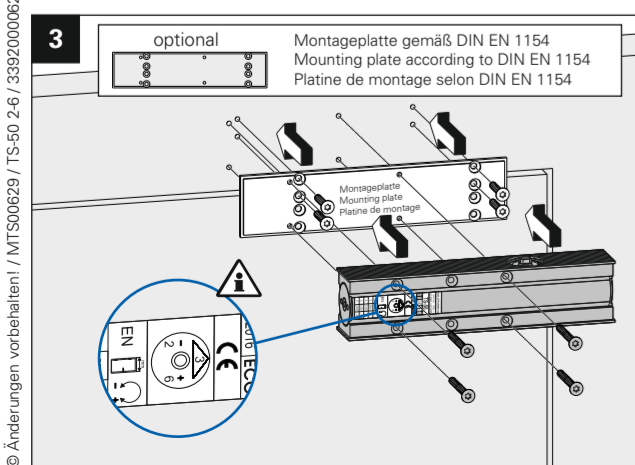
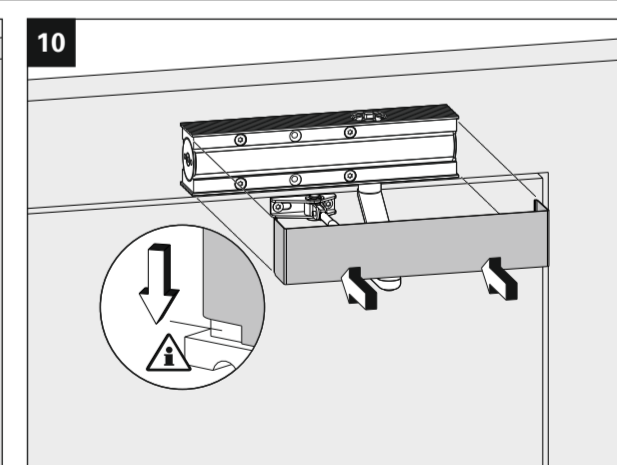
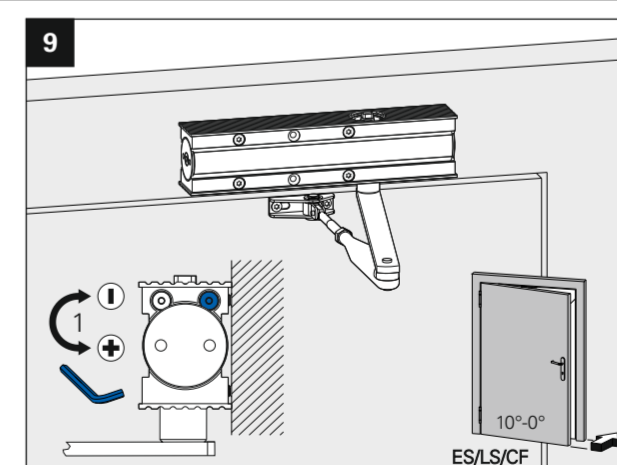
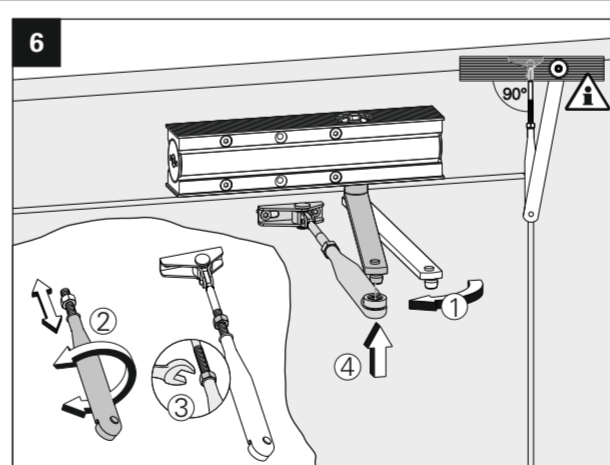
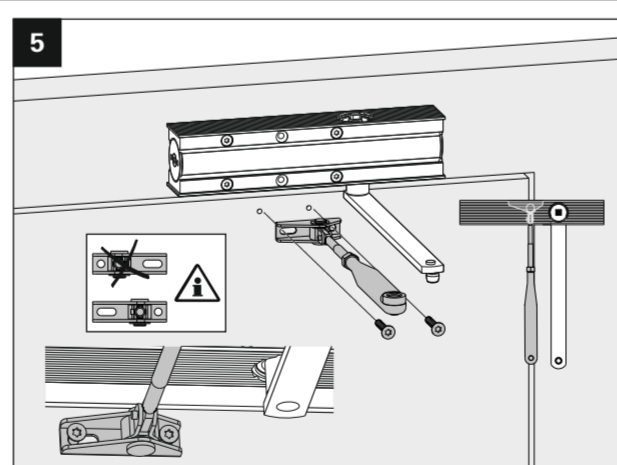
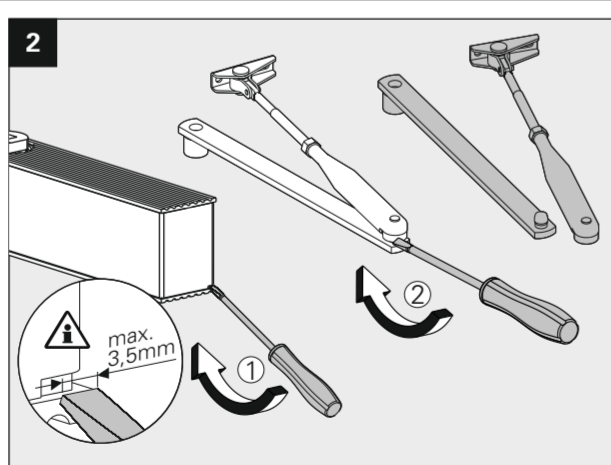
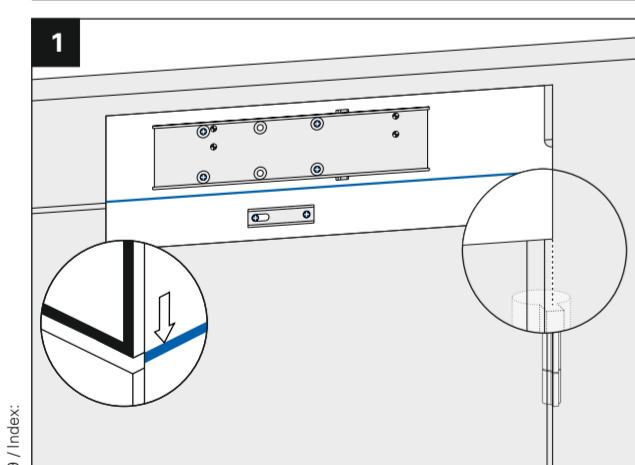
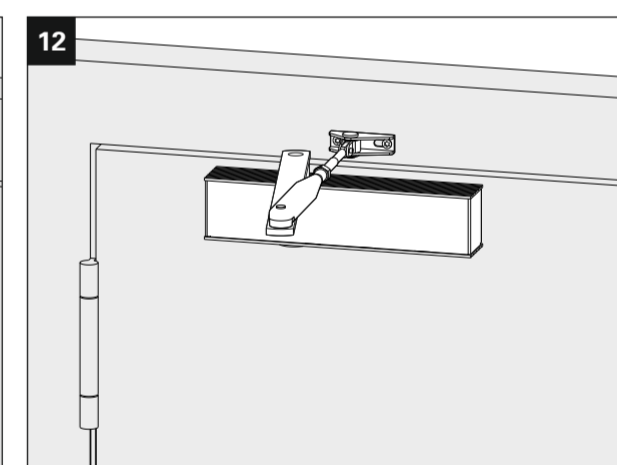
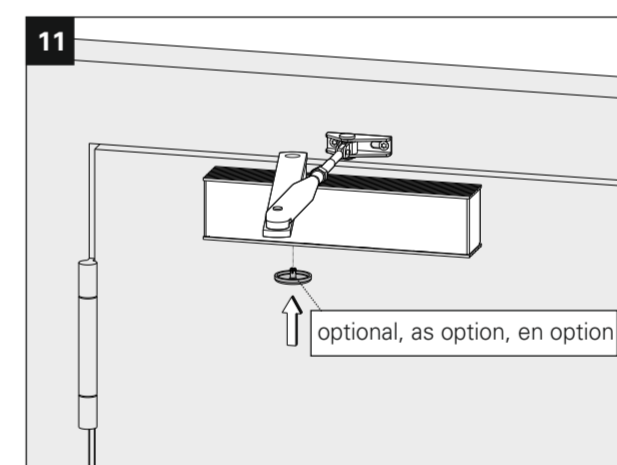
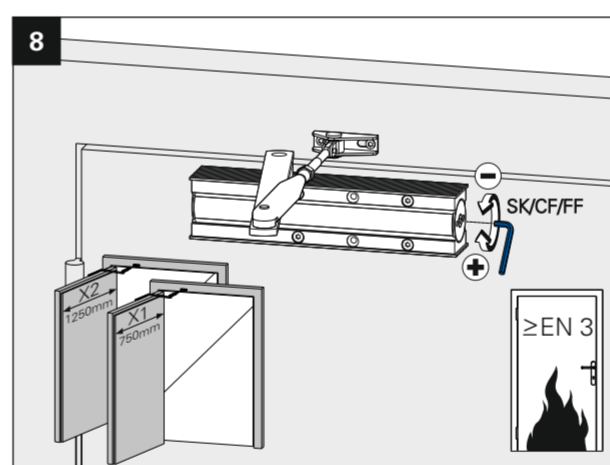
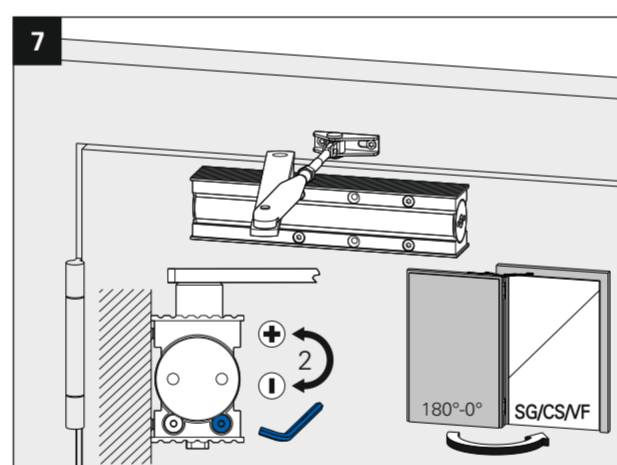
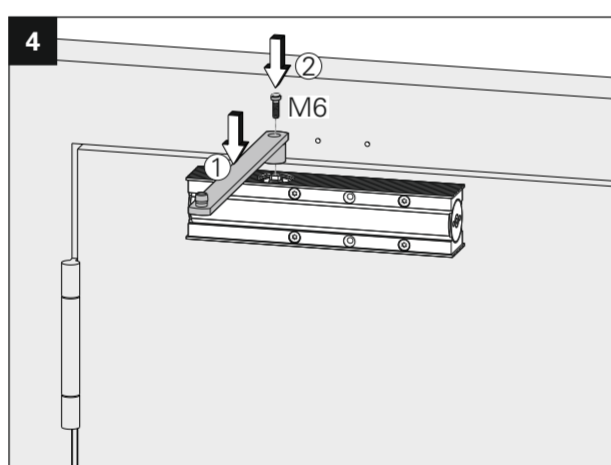
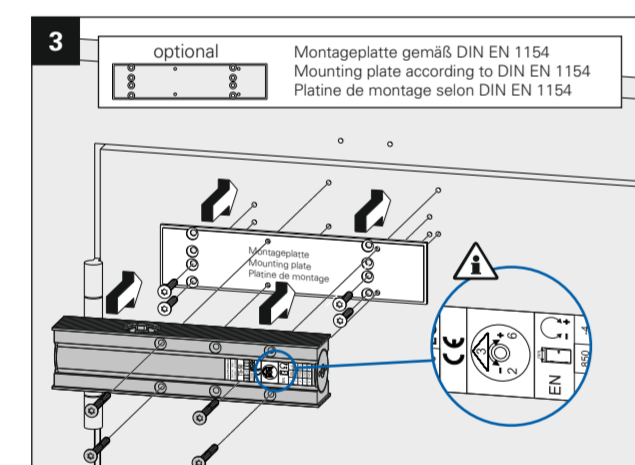
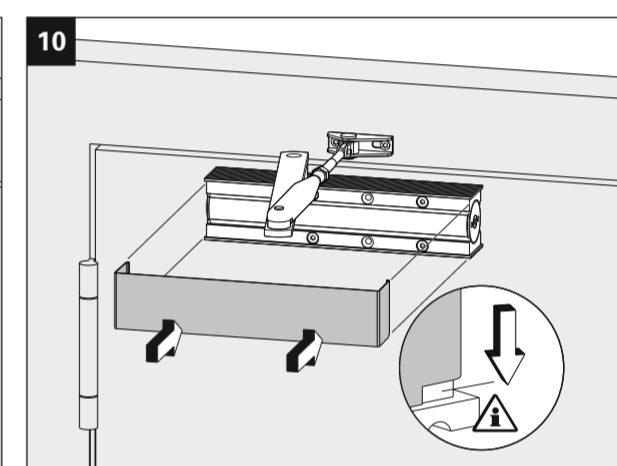
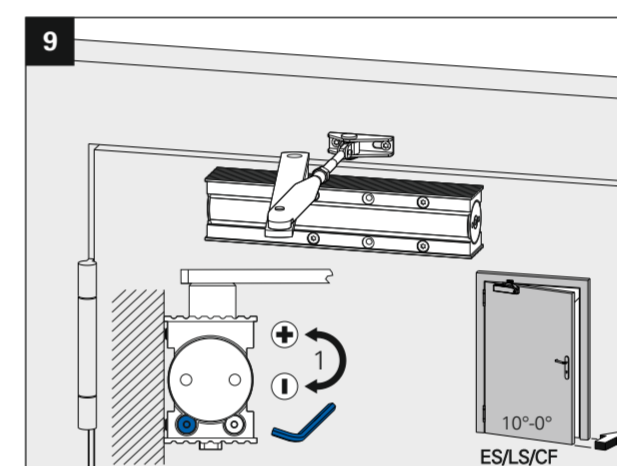
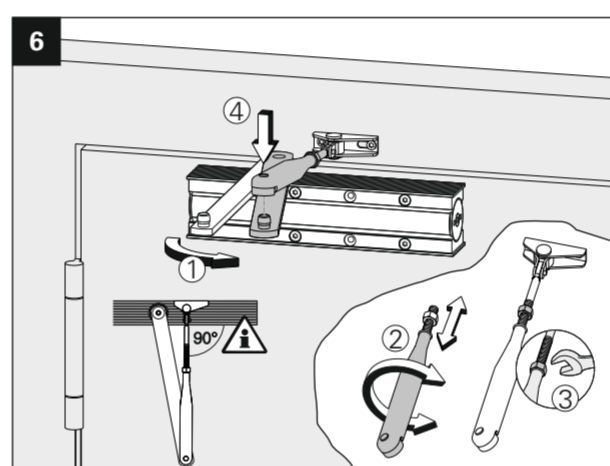
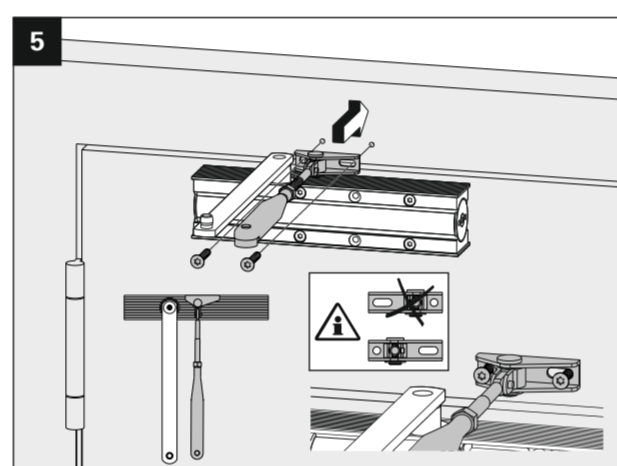
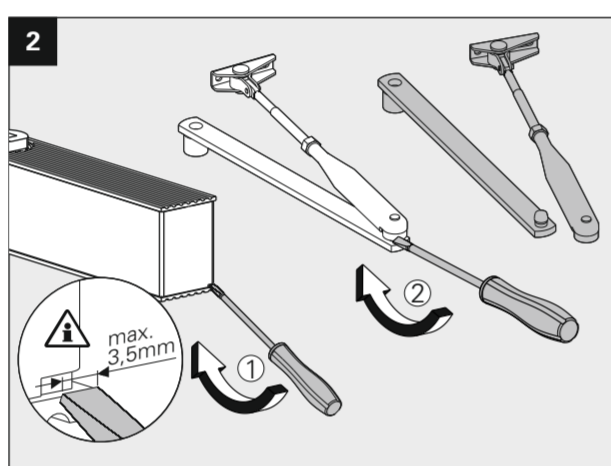
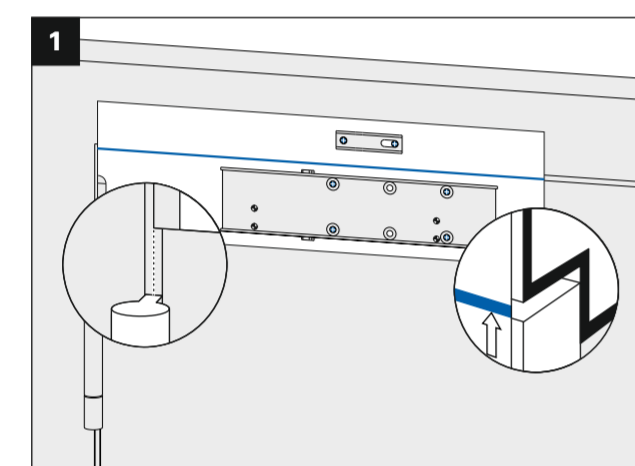



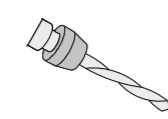

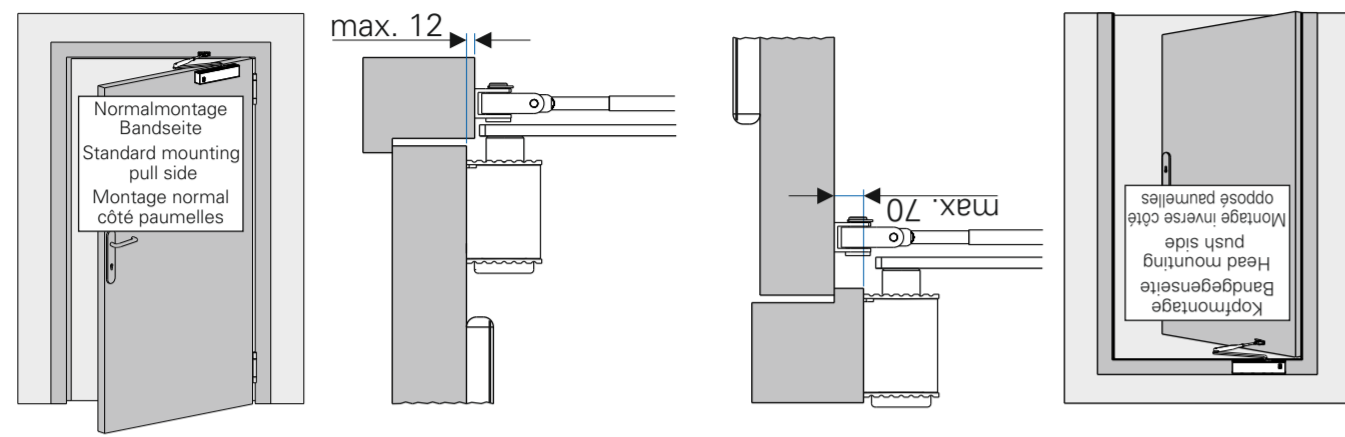
 Ø 2,5  
 Ø 4,2 (M5)

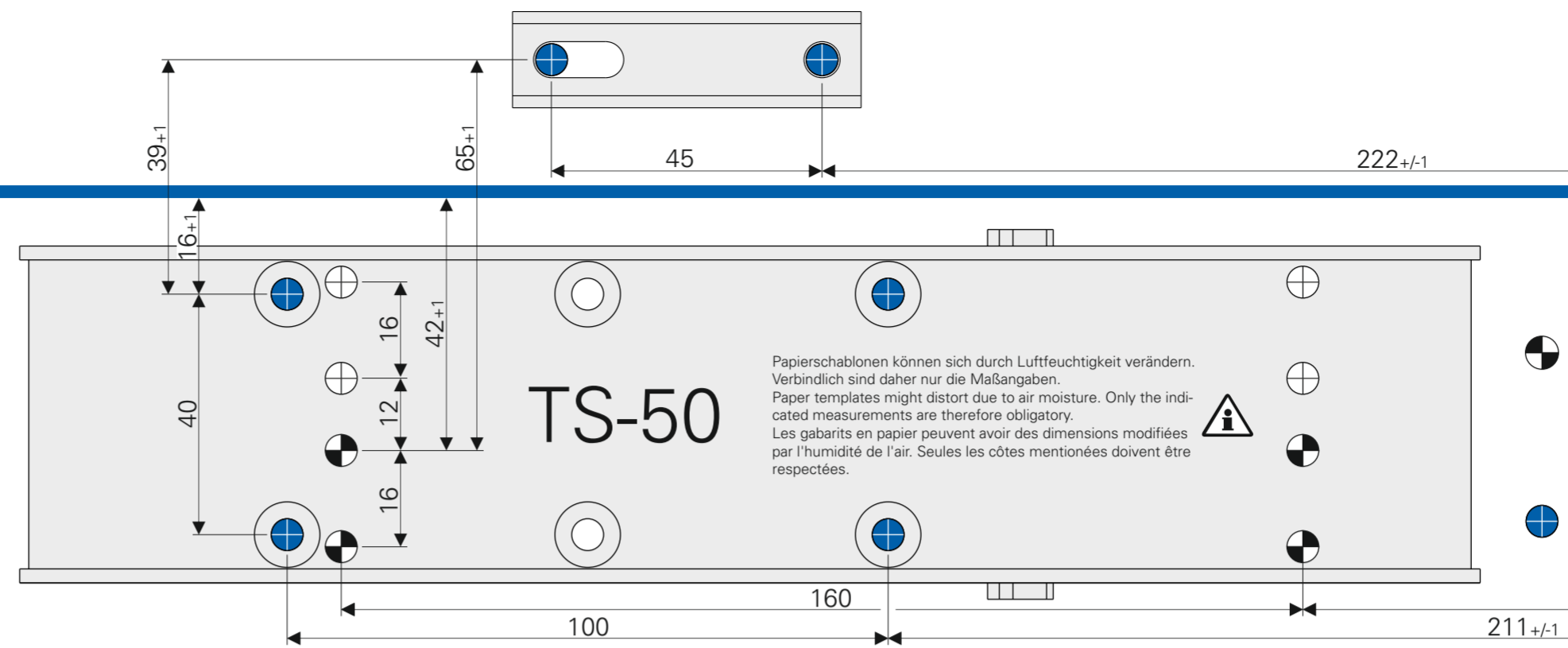

DIN rechts / right / droite



Bohrungen für Montageplatte gemäß Beiblatt 1 zur DIN EN 1154  
 Drillings for mounting plate according to supplemental sheet 1 DIN EN 1154  
 Alésage pour platine de montage selon supplément 1 DIN EN 1154

Bohrungen für Direktmontage  
 Drillings for direct mounting  
 Alésage pour montage direct

# TS-50 EN 2-6

	ECO Schulte GmbH & Co. KG Iserlohner Landstraße 117 D-58706 Menden	17
0432-CPR-00099-10	EN 1154:1996+A1:2002 / AC:2006	4 8 2-6 1 1 4

TS-50 EN 2-6	Türschließergröße Door closer size Force de ferme porte	Max. Türbreite Max. door width Largeur de porte max.	Umdrehungen Rotations Rotations
■ 2	850 mm	-3	
■ 3	950 mm	0	
■ 4	1100 mm	+3	
■ 5	1250 mm	+7	
■ 6	1400 mm	+11	

Für die Montage dürfen ausschließlich Originalteile des Herstellers verwendet werden. Die Montagearbeiten müssen gemäß Anleitung von einer qualifizierten Person durchgeführt werden. Bei Nichtbeachtung entfällt jeglicher Garantieanspruch. Diese Anleitung ist vom Monteur nach der Montage an den Betreiber weiterzugeben.  
 Only original parts have to be used. The assembly has to be made by a qualified person according to the mounting instruction. In case of non-respect the guarantee is invalid. This instruction is to be handed over to the operator by the fitter after assembly!  
 Impérativement utiliser la notice de montage fournie par le fabricant. La mise en œuvre et le montage doivent être exécutés par du personnel qualifié. Le non respect de ces règles annule catégoriquement tout droit de garantie. Cette instruction est à remettre par le poseur à l'exploitant après montage.

