

GS B



Papiersablonen können sich durch Luftfeuchtigkeit verändern. Verbindlich sind daher nur die Maßangaben.
Paper templates might distort due to air moisture. Only the indicated measurements are therefore obligatory.
Les gabarits en papier peuvent avoir des dimensions modifiées par l'humidité de l'air. Seules les côtes mentionnées doivent être respectées.

120 \pm 1

428,5

40,5 \pm 1

17,5 \pm 1

39

TS-15 B

205 \pm 1

100

Bohrungen für Direktmontage
Drillings for direct mounting
Alésage pour montage direct

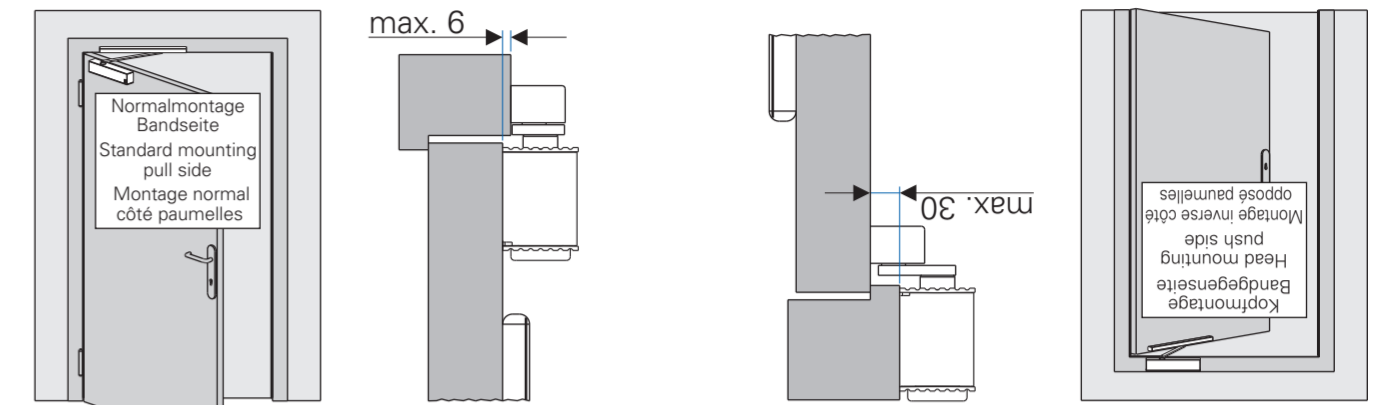

DIN links / left / gauche

TS-15 B

Abkürzungen	Abbreviations	Abréviations
SG	CS	VF
Schließgeschwindigkeit	Closing speed	Vitesse de fermeture
ES	LS	CF
Endschlag	Latching speed	Coup final

Für die Montage dürfen ausschließlich Originalteile des Herstellers verwendet werden. Die Montagearbeiten müssen gemäß Anleitung von einer qualifizierten Person durchgeführt werden. Bei Nichtbeachtung entfällt jeglicher Garantieanspruch.



Only original parts have to be used. The assembly has to be made by a qualified person according to the mounting instruction. In case of non-respect the guarantee is invalid.

Impérativement utiliser la notice de montage fournie par le fabricant. La mise en œuvre et le montage doivent être exécutés par du personnel qualifié. Le non respect de ces règles annule catégoriquement tout droit de garantie.

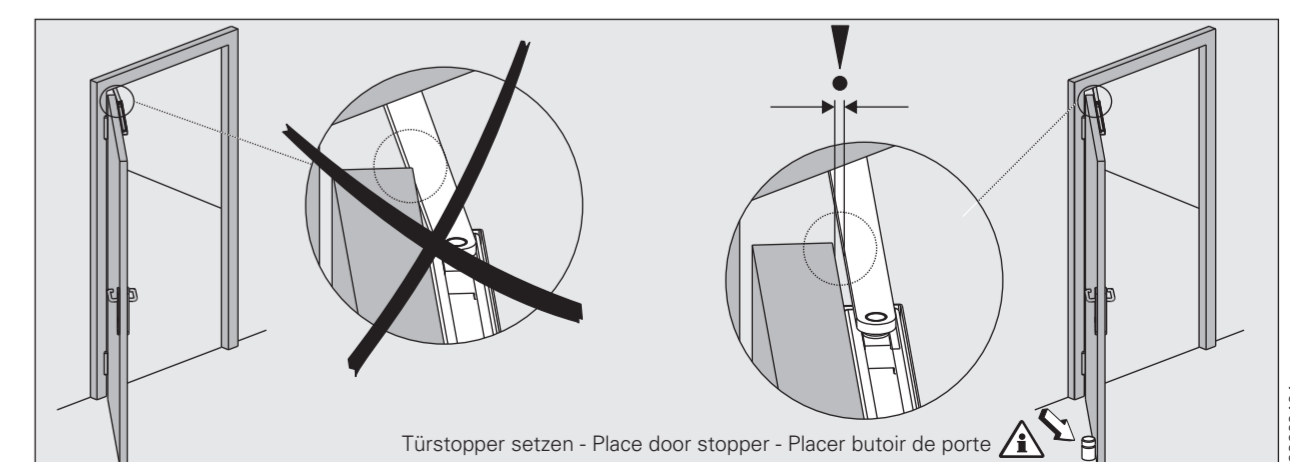
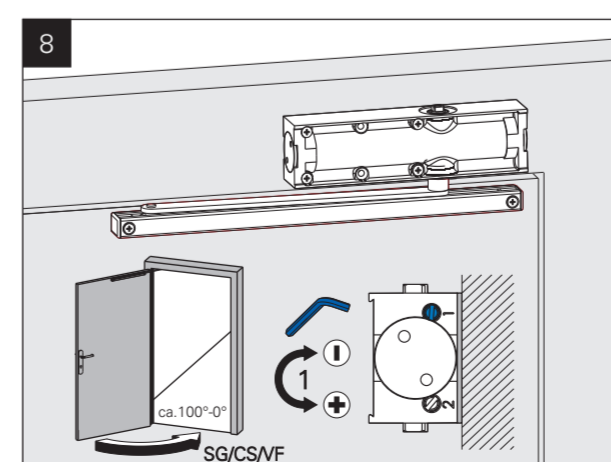
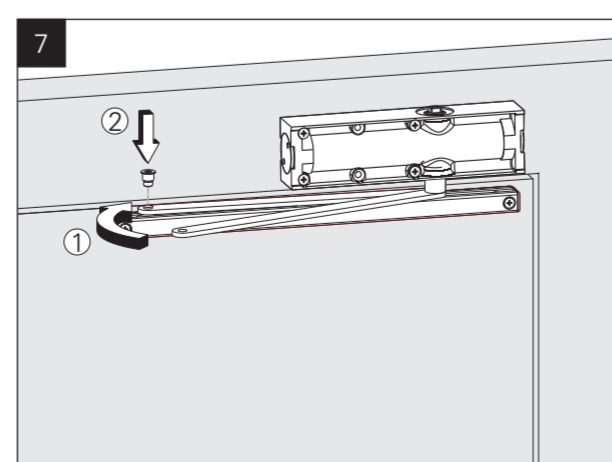
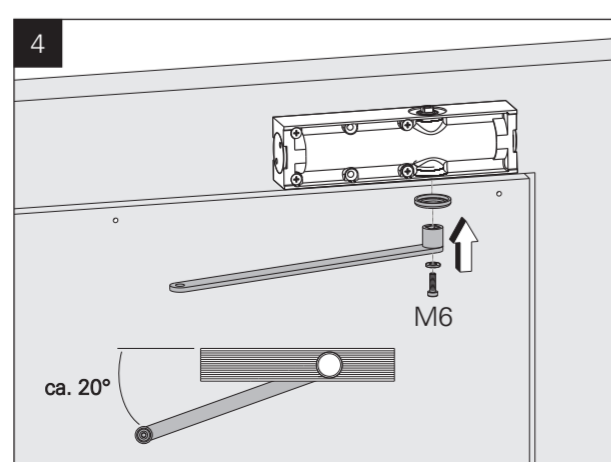
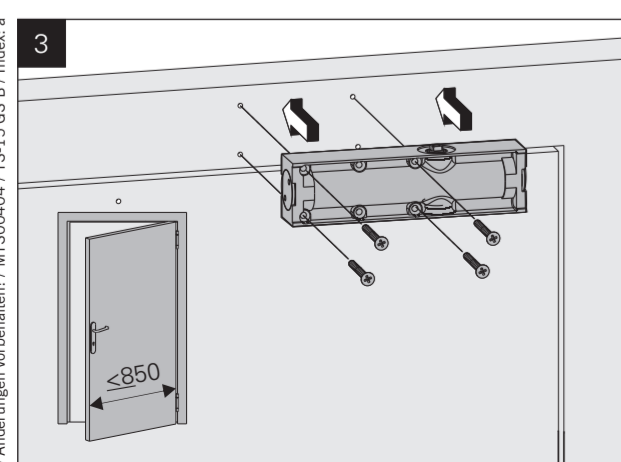
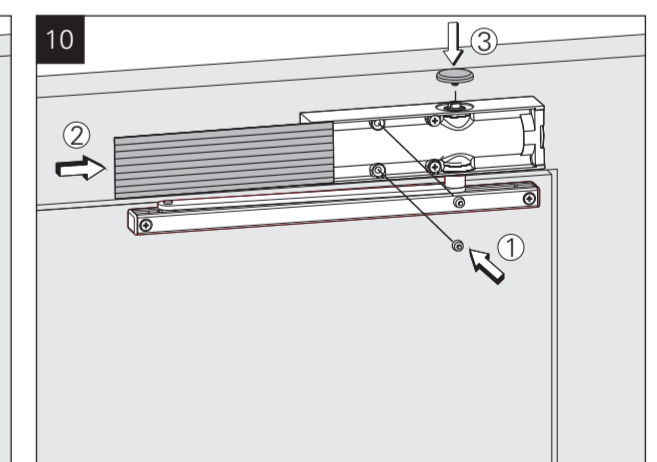
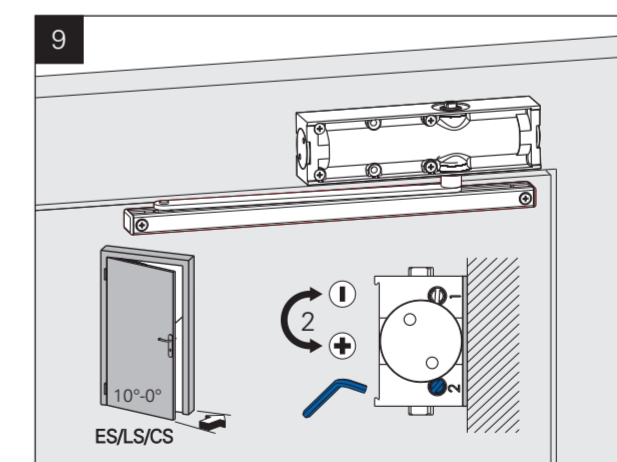
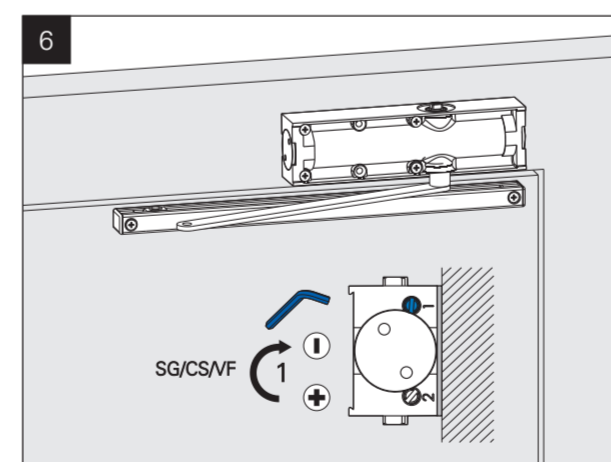
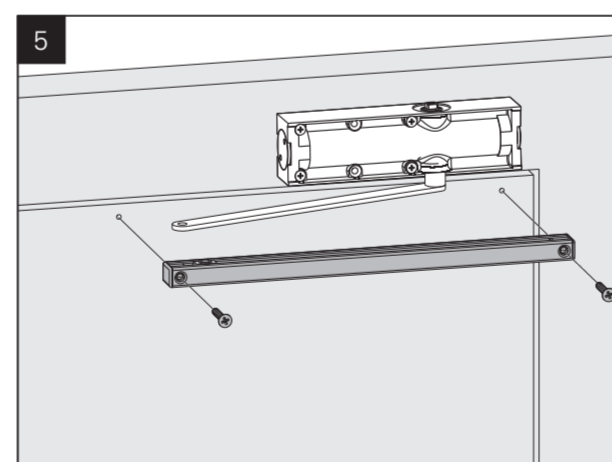
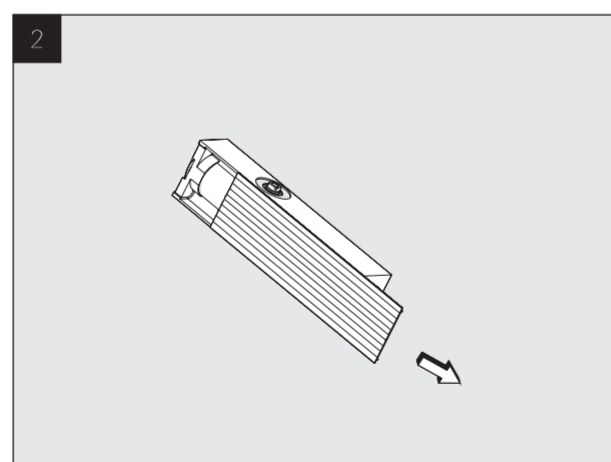
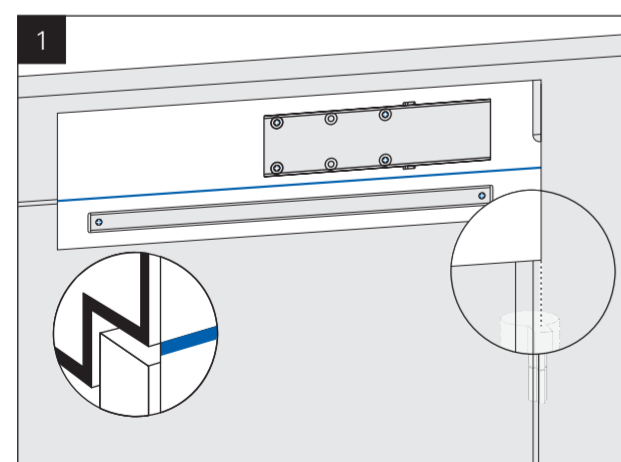
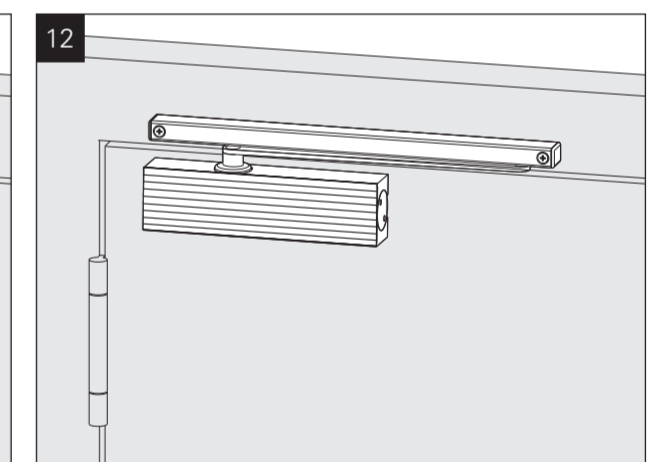
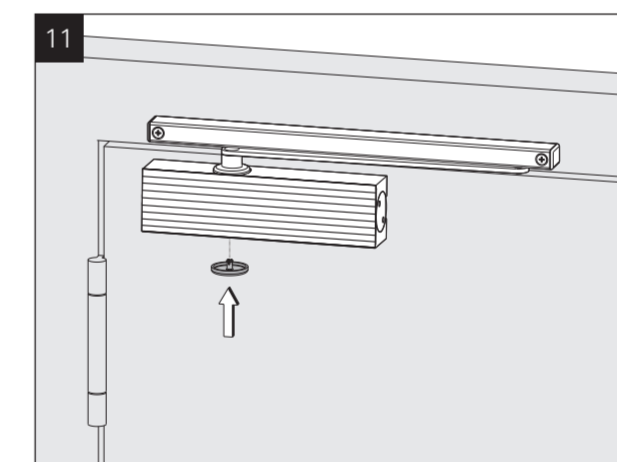
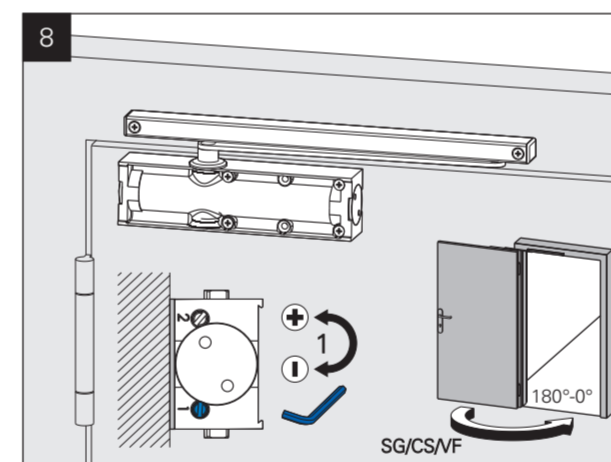
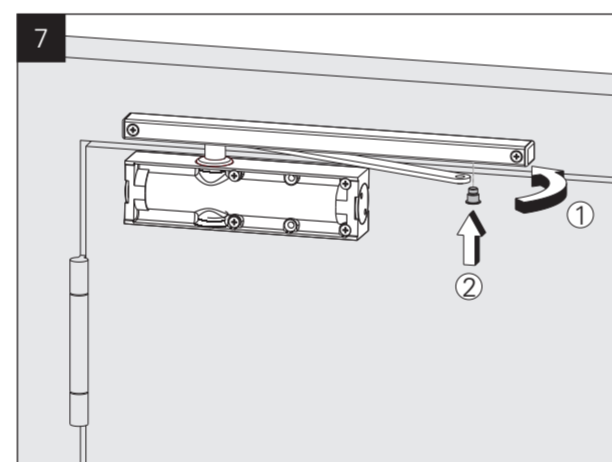
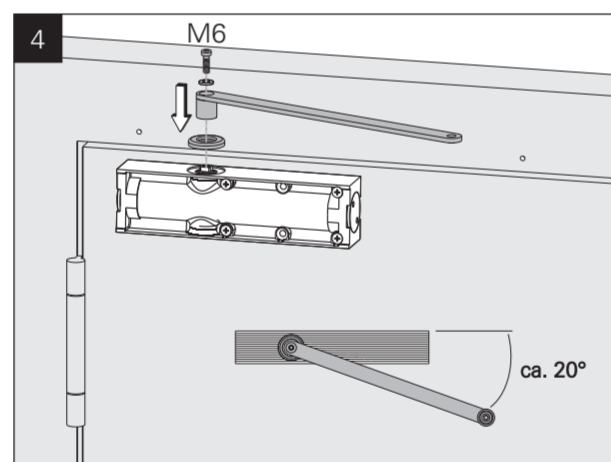
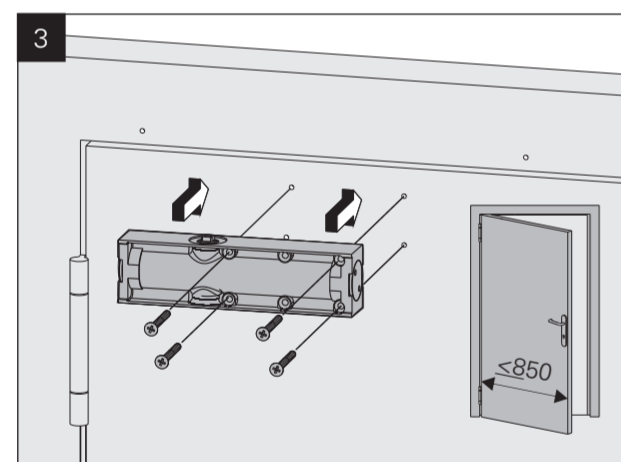
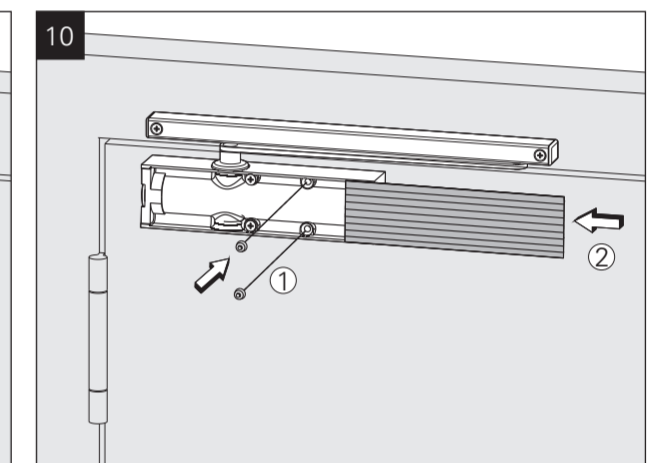
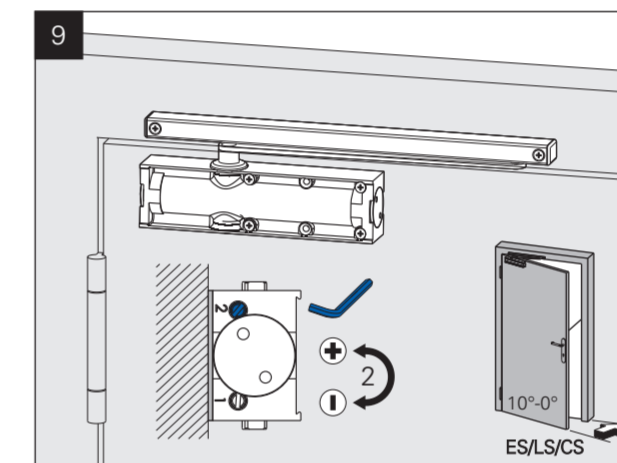
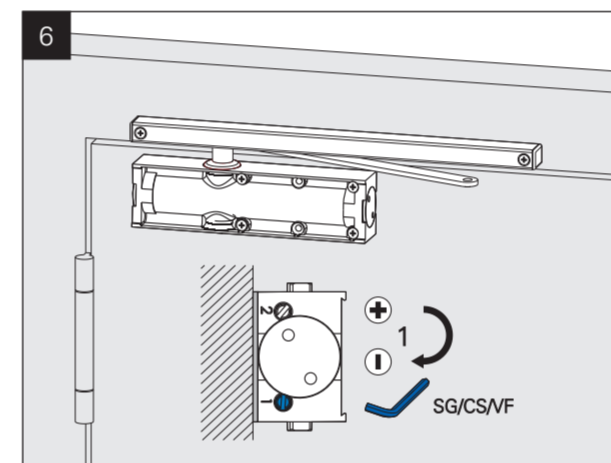
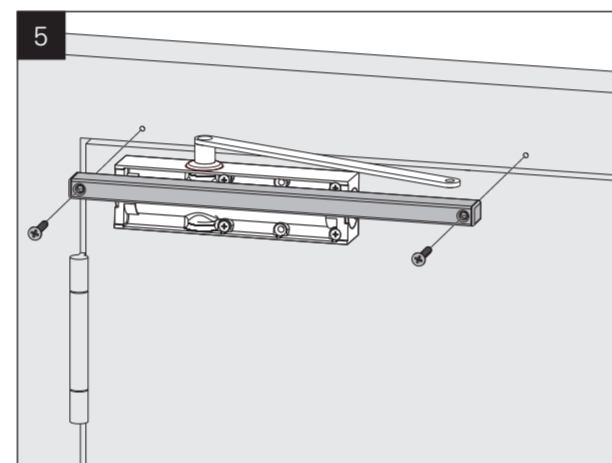
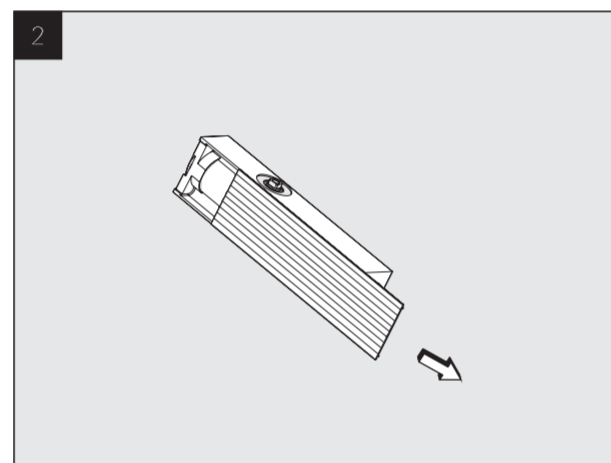
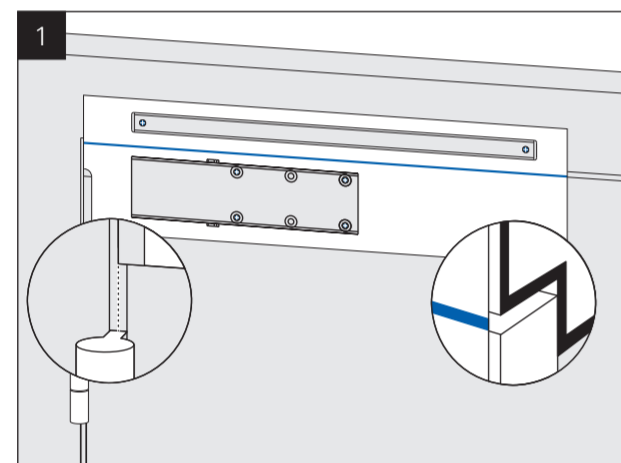

Türstopper setzen - Place door stopper - Placer butoir de porte

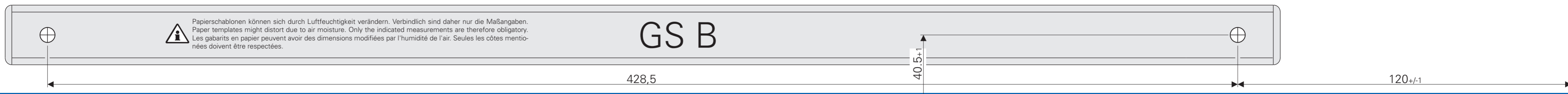

! Papiersablonen können sich durch Luftfeuchtigkeit verändern. Verbindlich sind daher nur die Maßangaben.
 Paper templates might distort due to air moisture. Only the indicated measurements are therefore obligatory.
 Les gabarits en papier peuvent avoir des dimensions modifiées par l'humidité de l'air. Seules les côtes mentionnées doivent être respectées.

GS B

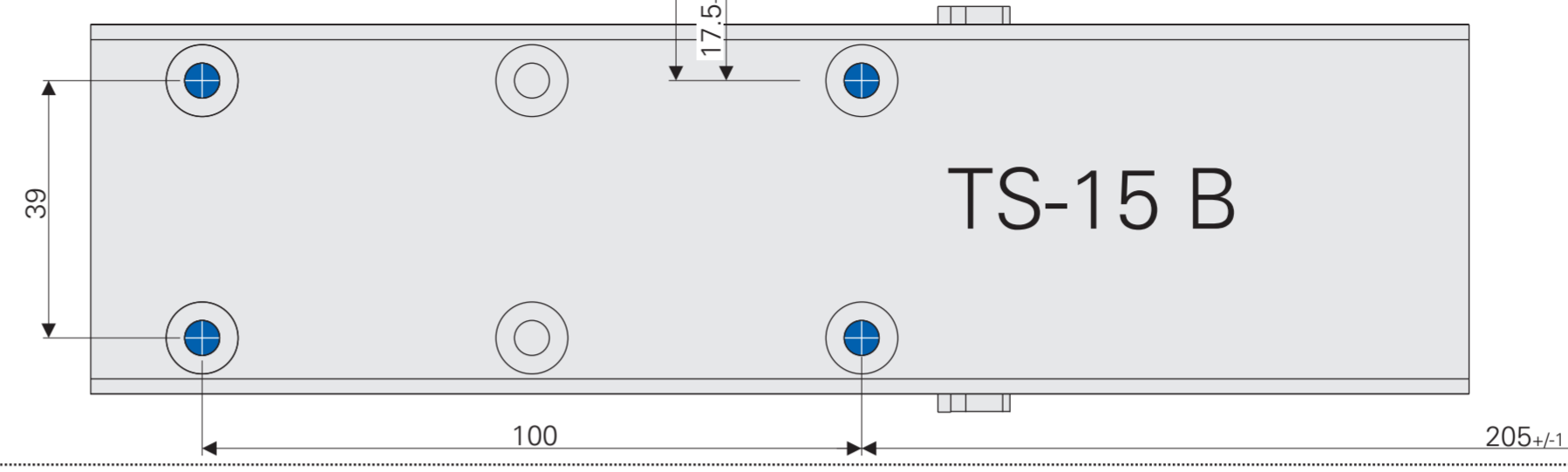
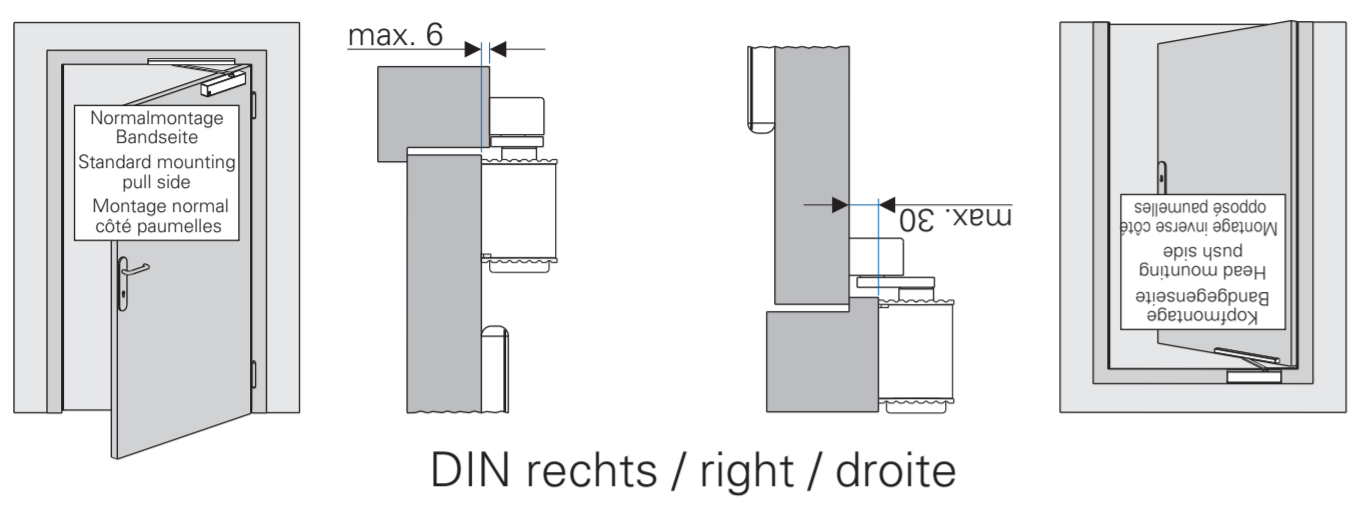

TS-15 B

+ Bohrungen für Direktmontage
 Drillings for direct mounting
 Alésage pour montage direct

TS-15 B

Abkürzungen	Abbreviations	Abrévations
SG	CS	VF
Schließgeschwindigkeit	Closing speed	Vitesse de fermeture
ES	LS	CF
Endschlag	Latching speed	Coup final

! Für die Montage dürfen ausschließlich Originalteile des Herstellers verwendet werden. Die Montagearbeiten müssen gemäß Anleitung von einer qualifizierten Person durchgeführt werden. Bei Nichtbeachtung entfällt jeglicher Garantieanspruch.

Only original parts have to be used. The assembly has to be made by a qualified person according to the mounting instruction. In case of non-respect the guarantee is invalid.

Impérativement utiliser la notice de montage fournie par le fabricant. La mise en œuvre et le montage doivent être exécutés par du personnel qualifié. Le non respect de ces règles annule catégoriquement tout droit de garantie.

