

ECO DOOR CLOSERS, CLOSING SEQUENCE SELECTORS AND HOLD-OPEN SYSTEMS

GENERATION III

■ SYSTEMTECHNIK FÜR DIE TÜR



INNOVATIVE MATERIAL

ER STAINLESS-STEEL DESIGN

Stainless steel was once primarily reserved for industrial buildings, but like many other materials, it has gained in popularity to become a sought-after choice in countless prestigious projects. The use of new techniques and architectural experimentation support this growing trend. Stainless steel finds its place wherever high reliability, functionality and hygiene are paramount. Despite the material's contemporary and technical associations, its appearance remains rather neutral, with its surfaces reflecting light and its colours blending seamlessly with the surroundings. In the years to come, stainless steel is destined to retain its irreplaceable role as a fundamental choice.

Corrosion and environmental protection

It is not just for visual appeal that we grind, matt and mirror polish our stainless-steel products at the end of the production process. When it comes to being corrosion-resistant, the finer the surface, the greater the resistance to corrosion.

Stainless steel also ticks all the boxes in terms of its environmental footprint. This is because its production is more resource-efficient compared to other materials and it is also 100 per cent recyclable, thereby seamlessly closing the material cycle.



EXCEPTIONAL DESIGN AT NO EXTRA COST



ECO **Newton TS-61**
and H slide rail with full cover

ECO **Newton TS-61 (3-6)**
with H slide rail



The stainless steel we use combines durability and innovative technology with environmentally conscious design. This sustainable material with bright prospects is the perfect choice not only for the environment's sake, but also for our customers to enjoy virtually a lifetime of longevity.

We have chosen to use this high-quality material as standard for our door closers and hold-open systems, all without passing on any extra costs to our customers.

THE HIGHLIGHTS

ECO **NEWTON**

Two bodies for the whole building

The ECO **Newton** door closer portfolio covers all door dimensions with only two basic bodies. In addition, end-mounted valve technology permits the door closer to be installed on the hinge or opposite hinge side in standard or frame installation (TS-41/31).

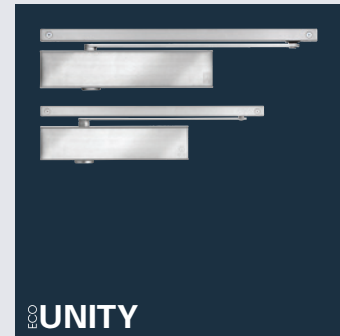

Combination of elegant materials

Elegant materials are standard with ECO **Newton**: The stainless steel cover and aluminium body unit of the new door closer generation are perfectly matched to one another – in an architecturally compatible form language.

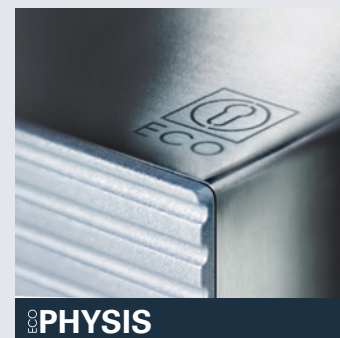

Intelligent stainless steel cover

ECOclic envelops the aluminium body unit with the power of spring steel. The cover conceals all of the adjusting elements and cannot be removed without tools, thus securing the door closer against unauthorised access.



Well-conceived assembly system

The special feature of the ECO **Newton** assembly system is that the mounting plate is completely concealed by the aluminium body of the door closer, thus making it invisible. The mounting plate has standardised drill holes that guarantee time-saving, secure and straightforward fixing.



Innovative valve technology

The new valve technology ECO valve offers a wide and precisely adjustable setting range. This means simple, high-precision and permanently secure adjustment of all parameters of the closing process using a conventional Allen key. With all ECO **Newton** door closers, the closing speed and latching speed are regulated via the ECO valve as standard. An additional valve stop prevents the valves being overtightened or screwed out.



Stainless steel full cover

The full cover is an optional stainless steel cover for the ECO **Newton** door closer and the respective slide rail. The overall appearance is perfected by a lever arm in a stainless steel design. A cover on the closer body unit is available for standard arm closers.



THE HIGHLIGHTS

ECO **NEWTON**

Saves resources

ECO **Newton** door closers are up to 1,000 grams lighter than comparable solutions. Their intelligent design and carefully planned use of materials significantly help to save resources – without compromising functionality, safety, security or quality.



Uniform finishing edge and colour design

The mounted slide rail and door closer are flush when the door is closed.

All materials are perfectly colour-matched – right through to the end caps on the slide rail. This allows ECO **Newton** door closers to be integrated harmoniously into every design context.

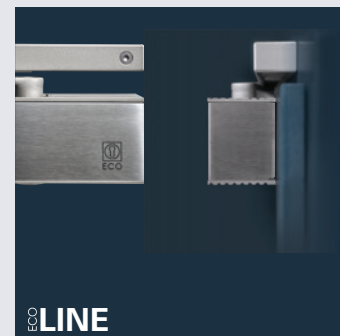

Versatile

The ECO **Newton VARIO** concept permits the use of all slide rail door closers and can even be combined with different door leaf widths. This way, optimum value for money can be achieved for each individual door situation.



Torx screw connection

The advantages compared with conventional cross-head and slot-head screws include a higher torque and faster and more sturdy fixing. The low risk of the driver slipping reduces damage to components. Torx minimises wear, combined with a technically attractive design.



Accessibility

DIN 18040-2
DIN SPEC 1104
Ö1600 – Austria
BS 8300 – England
PMR – France



Standardised quality

As with all ECO Schulte products, the door closers are manufactured in a quality management process certified in accordance with ISO 9001. This guarantees that top quality is produced and installed. Many door closer versions are suitable for use on fire and smoke control doors – and tested acc. to **EN 1154**. All products that are tested in accordance with valid European directives are identified by the CE mark.



ECO SCHULTE SLIDE RAILS



ECO GS-H

- Height-adjustable by up to 4 mm, for adapting to on-site construction tolerances
- With colour-matched end caps for an invisible screw connection
- Flush edge with DC body
- New 4 mm lever arm

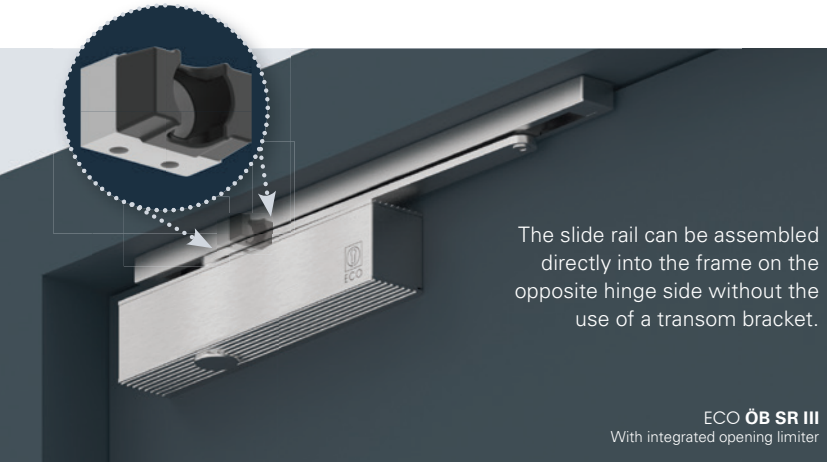

ECO GS-STM

- Slide rail for transom installation
- **Installation benefits:** No need for transom bracket, fewer screw connections, faster installation
- **Functional benefit:** An adjustable opening limiter (ECO ÖB SR III) is already integrated into the ECO GS-STM
- **Structural benefit:** The full-surface support of the GS-STM on the frame (direct installation) prevents the tilting moment in the transom bracket
- **Visual benefits:** No visible SFW, no colour differences, no visible screws from the front
- **Additional safety:** The omission of the SFW increases the clear passage height to reduce the risk of injury

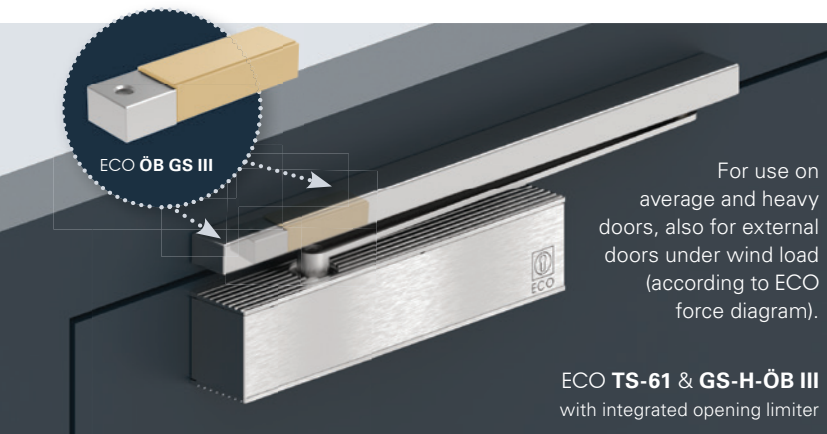

ECO GS-HF



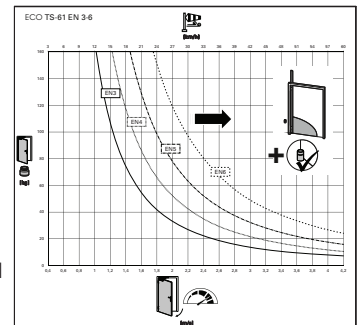





- Extended slide rail with universal mechanically adjustable opening limiter ÖB GS III.
- The limit angle can be adjusted by sliding within the slide rail.
- Opening dampers with new material for optimal absorption of opening forces.



ECO NEWTON

DOOR CLOSER (EN 1154)









Slide rail closers

Designation	Tests ¹	Size acc. to EN ²	Latching speed adjustment ³	Back check ⁴	Closing speed adjustment	Delayed action ⁵	DIN L + R / BS + BG ⁶
TS-62	 / 	2-5 continuously	adjustable from the front	adjustable	from the front	adjustable	yes / yes ⁷
TS-61 (3-6)	 / 	3-6 continuously	adjustable from the front	adjustable	from the front	adjustable	yes / yes ⁷
TS-41	 / 	1-4 continuously	from the side	fixed	from the side	–	yes / yes
TS-31	 / 	1-3 continuously	from the side	–	from the side	–	yes / yes
TS-15	–	1 / 2	from the side	–	from the side	–	yes / yes

Standard arm closers

Designation	Tests ¹	Size acc. to EN ²	Latching speed adjustment ³	Back check ⁴	Closing speed adjustment	Delayed action ⁵	DIN L + R / BS + BG ⁶
TS-50 (2-6)	 / 	2-6 continuously	from the side	fixed	from the side	–	yes / yes
TS-20	 / 	3 / 5	from the side	fixed	from the side	–	yes / yes
TS-14 EN	 / 	2 / 3 / 4	from the side	–	from the side	–	yes / yes
TS-15	–	2 / 3 / 4 / 5	from the side	–	from the side	–	yes / yes
TS-14	–	1 / 2 / 3 / 4	from the side	–	from the side	–	yes / yes

Concealed door closers

Designation	Tests ¹	Size acc. to EN ²	Latching speed adjustment ³	Back check ⁴	Closing speed adjustment	Opening angle	DIN L + R / BS + BG ⁶
ITS 420	 / 	2-4 continuously	from the top	–	from the top	120 °	yes / yes
ITS 630	 / 	3-6 continuously	from the top	–	from the top	120 °	yes / yes
ITS MG (2-4)	 / 	2-4 continuously	before installation	–	before installation	165 ° ⁸	yes / yes
ITS MG (2-5)	 / 	2-5 continuously	before installation	–	before installation	165 ° ⁸	yes / yes

Key: **1)** EN 1154 – CE-mark and fire-protection tested **2)** Door closer sizes acc. to European Norm (EN) **3)** Increases the closing force just before closing to ensure the door closes reliably **4)** Regulates the force necessary to open the door **5)** Convenient delayed action – e.g. for hotel room doors **6)** Left and right-hand installation (L+R) possible, as well as for hinge side (BS) or opposite hinge side (BG)

7) Please order BG (= opposite hinge side) model **8)** Dependent on door and frame construction

















ECO SCHULTE **CLOSING SEQUENCE SELECTOR & HOLD-OPEN SYSTEM**

When opening the passive leaf, brake wedges in the active leaf slide rail (mechanically independent of the door closer hydraulics) ensure that the active leaf stops as soon as the passive leaf is opened.

The patented solution allows the active leaf to still be pushed in both directions even with the passive leaf open, without affecting the system's function or service life. This makes the ECO SR III an almost vandalism-proof system and, as such, particularly suitable for use in public areas such as schools, offices and healthcare facilities.



SYSTEM OVERVIEW

Single-leaf systems					
Designation	Tests ¹	Function	Max. leaf width	Max. hold-open angle	Mounting type ²
ECO EF	 / 	Electromagnetic hold-open device (24 V)	1,400 mm	130 °	BS
ECO EF BG	 / 	Electromagnetic hold-open device (24 V)	1,250 mm	110 °	BG
ECO R III	 / 	Slide rail with integrated RSZ for ECO FTS III and on-site THM	1,400 mm	180 °	BS/BG
ECO EFR III	 / 	Electromagnetic hold-open system with integrated RM (230 V)	1,400 mm	130 °	BS
ECO EFR BG III	 / 	Electromagnetic hold-open system with integrated RM (230 V)	1,250 mm	110 °	BG
ECO IS EF	 / 	Electromagnetic hold-open device for ITS (24/48 V)	1,250 mm	95 °	concealed
ECO FTS III (3-6)	 / 	Free swing door closer (FS, 24 V)	1,400 mm	180 ° ⁴	BS/BG
ECO FTS-R III (3-6)	 / 	Free swing door closer (FSA, 230 V)	1,400 mm	180 ° ⁴	BS/BG

Double-leaf systems					
Designation	Tests ¹	Function	Max. hinge gap	Max. hold-open angle	Mounting type ²
ECO SR III	 / 	Closing sequence selector	2,800 mm	–	BS
ECO SR BG III	 / 	Closing sequence selector	2,500 mm	–	BG
ECO SR-R III	 / 	SR with integrated RSZ for ECO FTS III and on-site THM	2,800 mm	max. 175° ³	BS
ECO SR-R BG III	 / 	SR with integrated RSZ for ECO FTS III and on-site THM	2,500 mm	max. 120° ³	BG
ECO IS SR	 / 	Closing sequence selector for ITS	2,800 mm	–	concealed
ECO SR-EF	 / 	SR with hold-open device (24 V)	2,800 mm	130 °	BS
ECO SR-EF BG	 / 	SR with hold-open device (24 V)	2,500 mm	95 °	BG
ECO SR-EFR III	 / 	SR with hold-open system with integrated RM (230 V)	2,800 mm	130 °	BS
ECO SR-EFR BG III	 / 	SR with hold-open system with integrated RM (230 V)	2,500 mm	95 °	BG
ECO IS-SR-EF	 / 	ISR with hold-open device (24/48 V)	2,500 mm	95 °	concealed

Key: RM = smoke detector

1) EN 1155 – CE mark and fire protection authorisation **2)** BS = Hinge side / BG = Opposite hinge side **3)** Kept open via separate magnetic clamp for door according to approval. Door opening angle depends on the door or frame construction as well as structural situations (walls, etc.). Use of a release button (HAT 02) is mandatory. **4)** Refers to max. opening angle in free swing function



ECO closing sequence selector (EN 1158)



STAINLESS STEEL FULL COVER ECO **COVER²**

The full cover is an optional stainless steel cover available at additional cost for the ECO **Newton** door closer and the respective slide rail. The overall appearance is perfected by a lever arm in a stainless steel design. A cover on the closer body unit is available for standard arm closers.





INTELLIGENT STAINLESS STEEL COVER **ECOCLIC**

ECOclíc envelops the aluminium body unit with the power of spring steel. The cover conceals all of the adjusting elements and cannot be removed without tools, thus securing the door closer against unauthorised access.

ECOclíc
for body



Alternative: ECO ER full cover
for body and slide rail



FREE SWING DOOR CLOSERS WITH GS-HF SLIDE RAIL

ECO **FTS III** (EN3-6) EN1155

- 4 mounting types, one locking body:
 - Door leaf mounting hinge / opposite hinge side
 - Frame installation hinge/opposite hinge side
- Combined with ECO slide rails:
 - GS-HF and ECO SR III
- Opening angle up to 180°
- Free swing function activated from 1° opening angle
- Proven ECO **Newton** design matching the ECO **Newton** generation of door closers
- Optional full cover made of stainless steel (V2A) for FTS body and slide rail



ECO **FTS III**
without slide rail



ECO **FTS III** with GS-HF slide rail
(with surface-mounted cable connection)

FREE SWING DOOR CLOSERS WITH ECO-R II

ECO **FTS-R III** (EN3-6) EN 1155, DIBt aBG

ECO is launching the FTS-R III for use as a hold-open system with free swing function. This tested (EN 1155) and approved (DIBt type approval) hold-open system consists of the ECO FTS III and the new ECO R III slide rail with integrated smoke detector. The FTS and ECO R III can be connected internally or surface-mounted.

- For the frame installation version, there is the combination of ECO FTS III, GS-HF and ECO RSZ III
- For double-leaf applications, the ECO FTS III can be combined with the ECO SR-R (BG) III or SR-EFR-1S (BG) III slide rails.



ECO **FTS III + ECO R III, DL = DR** Normal installation, hinge side = opposite hinge side
(with concealed cable connection)

THE VERSATILE ALL-ROUNDER IN SMOKE AND HEAT EXTRACTION

FTA ECO-VENT TS-62

Object doors have many challenges, particularly when escape routes have to be combined with both smoke/heat extraction requirements and security. The new **FTA ECO-Vent** meets all these challenges with one system. It operates in day-to-day operation like a standard door closer with the highest level of access convenience; in the event of a panic, it operates like an escape route opener and, in the event of smoke extraction, like a heat and smoke extraction opener.

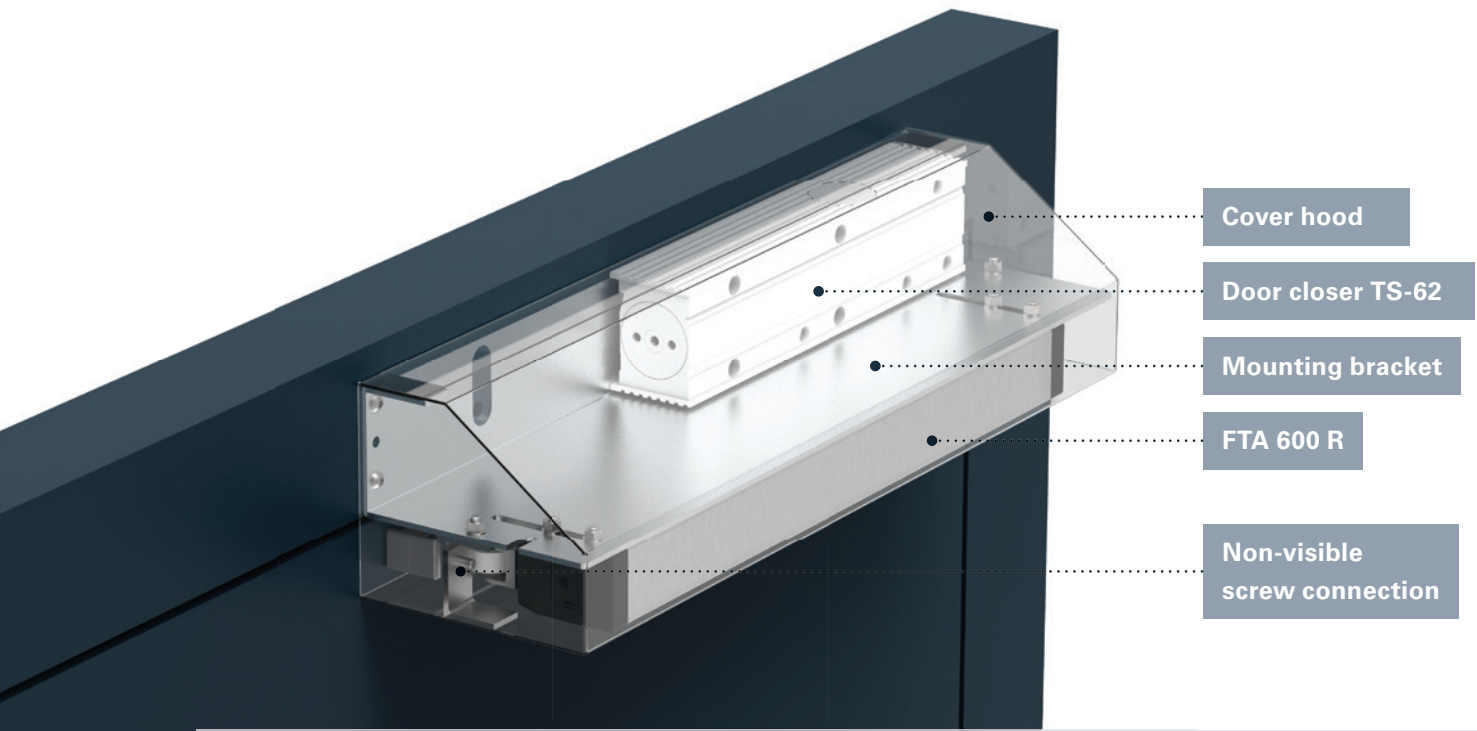

- Cover hood
- Door closer TS-62
- Mounting bracket
- FTA 600 R
- Non-visible screw connection

<p>Supply air opening for natural smoke and heat extraction systems with standard door elements</p> <ul style="list-style-type: none"> ▪ Standard-compliant and space-saving solution ▪ Opening angle of 90 degrees ▪ Cost-effective compared to automatic doors <p>Use of standard components</p> <ul style="list-style-type: none"> ▪ Simplifies storage and lowers operating and maintenance costs 	<p>The knuckle of the retractable arm drive runs along the slide rail of the door closer</p> <ul style="list-style-type: none"> ▪ Time- and money-saving installation through unique concealed assembly of the door closer and retractable arm drive ▪ Both components fitted on the same level <p>Networking capability</p> <ul style="list-style-type: none"> ▪ Compatible with all Aumüller products as well as all those from other common smoke and heat extraction system providers
---	--

Smoke extraction concept

For smoke extraction concepts based on natural uplift principles, precisely coordinated opening of doors and windows is necessary to ensure that poisonous gases escape from the building as quickly as possible. Over a certain period, this produces stable, low-smoke air layers near the floor that allow people to escape by themselves, thus saving many lives. Smoke extraction also makes the fire brigade's job more efficient and prevents or at least delays the dreaded flash-over, in which pyrolysis gases can ignite suddenly.

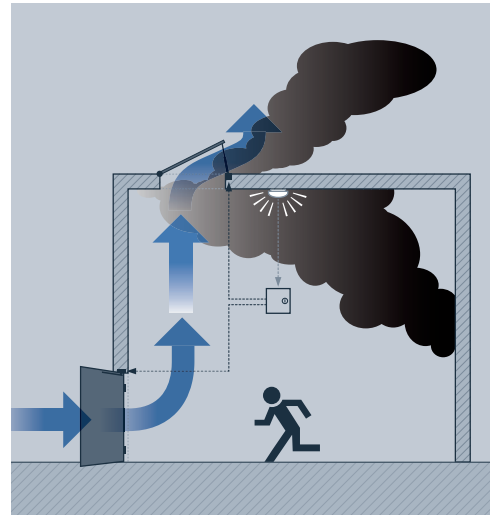

Time- and money-saving installation through concealed assembly of the door closer and retractable arm drive.



Easy retrofit in one product. No floor-mounted door closer or integrated door closer required.



Unique – all components on one side. Door closers with FTA are fitted on one level in the inside of the door only.



The advantages compared with conventional cross-head and slotted-head screws include a higher torque. Torx minimises wear, low risk of driver slipping, thus minimised damage to components.



Simple, high-precision and permanently secure adjustment of all parameters of the closing process using a standard Allen key.



This product can be installed on escape route doors with RWA openings and also fulfils the standards for an escape route, automatic opening and normal door functions as per DIN SPEC 1104.



The entire product is covered with an elegant stainless-steel cover.



Aumüller plug: Contains a strain relief system as per DIN EN 60335-1 and is also secure against being twisted; the locking hooks prevent the plug from being pulled out. This plug is compatible with all Aumüller products.

ELECTROMOTIVE SWING LEAF DOOR OPERATOR ECO ETS

Harmonious door movement:
motor-driven opening and controlled closing.

The new **ETS** from ECO is a powerful, low-noise, electric motor drive for heavy interior and exterior doors up to 400 kg (250 kg for fire protection / smoke protection doors). Equally suitable for new systems and modernisations.

Models and functions:

- Slide rails pushing (BG) and pulling (BS)
- 1- and 2-leaf systems with continuous cover
- Integrated, concealed closing sequence selector for fire/smoke protection doors (in the universal cladding)
- Integrated, concealed smoke detector
- Easy operation with illuminated program selection buttons in the side cover (automatic, always open, manual, exit and night)
- Plug + Play, set-up of functions with LCD
- Adjustable starting force and closing force amplification
- Adjustable start delay (motorised lock, closing sequence)
- Connectable wind load compensation, max. wind speed 80 km/h (320 Pa)
- Push & Go function or servo support can be set

Electromotive swing leaf door operator						
Designation	Tests	Size acc. to EN	Max. door weight	Wind load compensation	Mounting types	Integrated RM
ETS 42	EN 16005	2–4	150 kg	no	Frame installation Door leaf installation	no
ETS 42-R	F DIN 18263-4 EN 16005	2–4	150 kg	no	Frame installation Leaf installation	no
ETS 73	EN 16005	3–7	400 kg	yes	Frame installation Leaf installation	no
ETS 64-R IRM	F DIN 18263-4 EN 16005	3–6 / 3–5	250 kg	yes	Frame installation	yes
ETS 64-R IRM-SRI	F DIN 18263-4 EN 16005 EN 1158	3–6 / 3–5	250 kg	yes	Frame installation	yes





ETS



ECO Website



ECO Finder

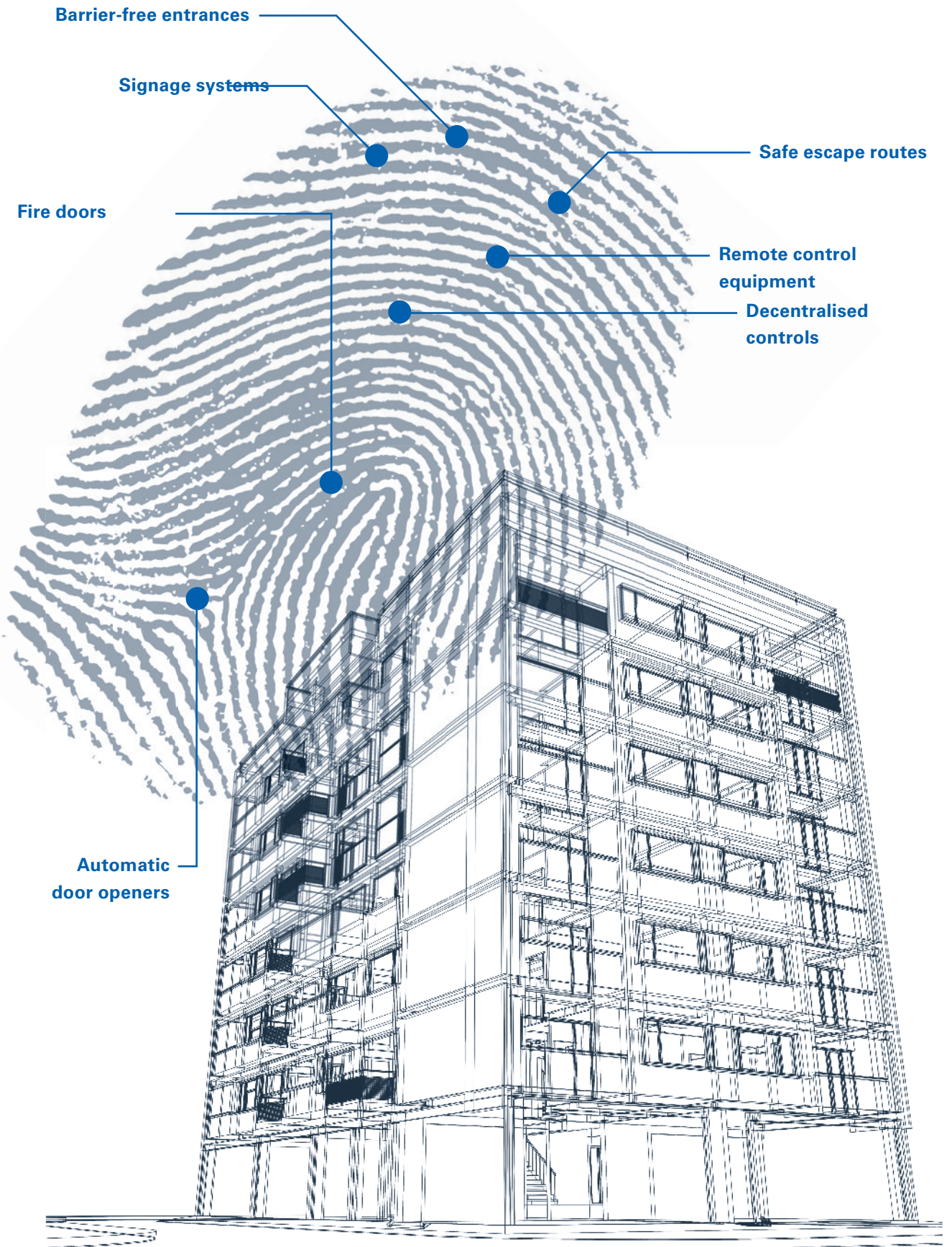

IDM – INTELLIGENT DOOR MANAGEMENT

ALL OPTIONS ARE OPEN

Doors control access into and within a building. What could be more logical than automating this access or even integrating it into the building management system? Visitor flows can be more effectively controlled and monitored this way – in all situations, in everyday operations as well as in emergencies.

Mechanics, mechatronics and IT are merging at our company under the name **ITM – Intelligent Door Management**, which is producing revolutionary complete packages with corresponding **engineering and service products**.

ITM – solving complex tasks

Each building is a highly individual project that reflects the use, needs and aesthetic values of its owners and users. By extension, this means that behind every door there is an extensive catalogue of requirements made up of user needs and security architecture. **Only networked doors can articulate a response to increasingly complex demands.**

But this complexity requires specialists in every subsection. ECO Schulte is fully committed to upholding the **expertise of the specialist** and to concentrating on its core business. We cooperate closely with other medium-sized specialist enterprises to tackle the challenges of complexity.

ECO FTI emergency exit door terminal for networked and time-controlled escape routes according to EN 13637



From multi-storey car parks to clinics and from offices to banks: the level of door networking must be developed individually for each building.

ECO SCHULTE QUALITY

All ECO door closers and systems are tested and certified according to the latest European standards and are therefore compliant with the most current European requirements for functional safety. This means they can be used as surface-mounted systems on all fire and smoke control doors made of steel, aluminium or wood.

Further certificates for our products can be found online at: zertifikate.eco-schulte.de



ECO certificates

All ECO products are certified. Scan this QR code for quick access to the relevant documents as downloadable PDFs.



ER UNIFORM FINISH

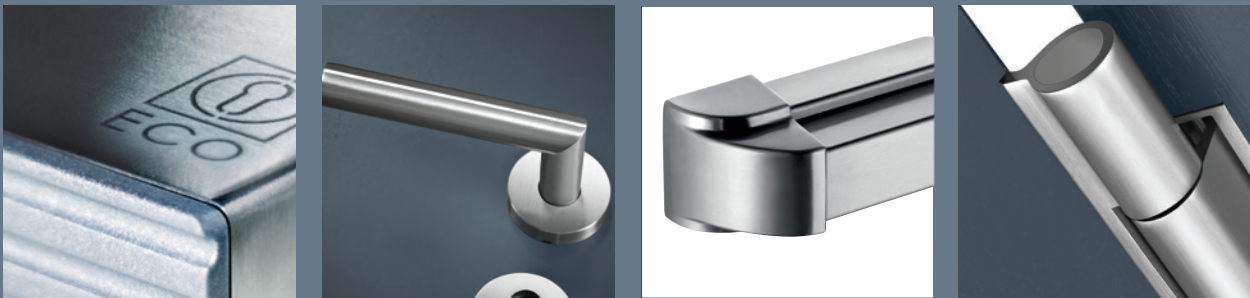

ECO Schulte sees the door as a system, and this system comprises all functional elements that make a door functional. In all its stainless-steel products, ECO pays meticulous attention to detail and refines the stainless-steel surfaces of door closers, fittings, panic bar handles, and hinges with a uniform structure. This ensures that the finely crafted finish of a door closer or hinge blends in seamlessly with that of our lever handle sets.



ECO REFERENCE PROJECT

MOTEL ONE

BERLIN



The Motel One Berlin-Alexanderplatz is just a stone's throw from the TV Tower, Red City Hall and Berlin Cathedral. The Alexanderplatz S-Bahn and U-Bahn station connects the hotel with Museum Island and the Brandenburg Gate, as well as with the different districts of the city. Alexanderplatz is emblematic of the diversity and contrasts of life in the big city.

The style of the Motel One Berlin-Alexanderplatz is characterised by the cultural diversity, contrasts and urbanity of the cosmopolitan city of Berlin. Only high-quality products were to be used, which fit seamlessly into the design concept in compliance with all current EN standards and offer visitors a high level of access convenience.

The ECO **Newton** door closer series was the perfect choice for this project. These door closers are specially designed for highly frequented function doors. They combine elegant design, functionality and maximum opening convenience.

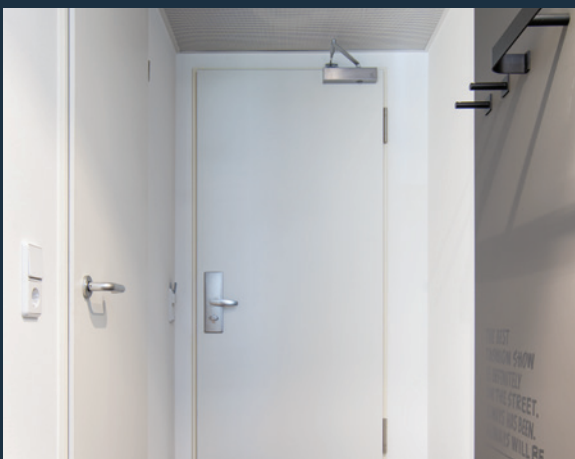

PRODUCTS

- Door closer **TS-61**
- Electromagnetic hold-open device with smoke detector **EFR with TS-61**
- Door closer **TS-20**

ECO REFERENCE PROJECT

INFINITY OFFICE

DÜSSELDORF



The Infinity Office on Düsseldorf's Schwannstraße, on the renowned Kennedydamm, offers around 19,000 square metres of rental space on a plot spanning just under 8,000 square metres. What makes this building so special is its free-form structure in a figure-of-eight shape.

Linking modern architecture with technical expertise. The building is designed to allow all users to concentrate 100% on their work.

The professional planning, advice and sampling from ECO Schulte were second to none, as was the holistic approach. The project incorporated all types of functional doors from the company's own product portfolio, from both a purely mechanical and an automatic point of view.

PRODUCTS

- Door closer **TS-62**
- Electromagnetic hold-open device with smoke detector **EFR III with TS-62**
- Electromotive swing leaf door operator **ETS-64-R**
- OGL and SGL Click handle on rose sets
- GBS locks
- Horizon OBX-18 object hinges
- Door stops for the floor and wall



ECO door management

Our online 'ECO door management' service is designed to support you at every stage of the planning process.

A wealth of information on our door technology products can be found in just a few clicks in the ECO Finder. Filters focus your search and make it easier for you to find the products you are looking for.

You can also download brochures containing detailed product descriptions and technical data.



Interactive cable plan

- A new interactive cable plan includes all essential information about control and safety elements, including cable cross-sections.
- Users can simply click on the form fields to add or remove the corresponding functional element along with its wiring.
- The result is a professional cable plan containing all crucial details for the builder, architect and electrician.

These cable plans (single- and double-leaf) are available for the following systems:

ECO **FSA III** ECO **ETS 42/73** ECO **ETS 64-R/IRM**

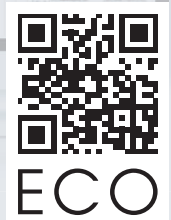



ECO Support

Friendly service and support are all part of our corporate culture.

Your ECO contact for service

+49 2373 9276 - 899
eco-service@eco-schulte.de

Your ECO contact for intelligent door management

+49 2373 9276 - 6099
itm@eco-schulte.de

ECO Schulte – Service



ECO Schulte – **ORGADATA** A CLICK AHEAD

Orgadata's flagship product is the CAD program LogiKal® – a software designed for window, door, and facade construction.

Within LogiKal®, users can create calculations, orders, construction drawings, and production instructions for their processing centres.

The ECO product range is now available in an updated version within LogiKal®, including all new products.

ECO Schulte GmbH & Co. KG

Iserlohner Landstraße 89

D-58706 Menden

Telephone +49 2373 9276 - 0

Telefax +49 2373 9276 - 40

info@eco-schulte.de

www.eco-schulte.de

Ihr Firmeneindruck

GO DIGITAL

I'm also available in digital
format.

■ SYSTEMTECHNIK FÜR DIE TÜR

